



exo183MGETR

EXO Tracer



The EXO Tracer is an industrial camera with a fully functional lens control (focus, zoom, aperture). Lens mount is a Micro Four Thirds (MFT) mount. The excellent thermal concept of the EXO qualifies for a operating temperature of up to 60°C.

The MFT beam geometry on the sensor side of the lens works in perfect harmony to the high sensitive Sony IMX sensors. A nearly perfect flatfield is the compelling result. Together with up to 72dB dynamic range and up to 12 MP resolution, the Tracer delivers excellent image quality.

Lens control and integrated strobe controller are integrated into the camera's GenICam 3.0 tree as properties. Any GenICam-driven software is immediately able to use lens control and strobe controller without additional drivers.

Technical Highlights

Rich set of features

- > Full control of lens (focus, zoom, aperture)
- > Global shutter
- > Monochrome and color versions (Bayer Pattern)
- > Various trigger (int./ext./free running) and exposure modes
- > Logic-Trigger functions (PLC)
- > Adjustable gain, auto gain and auto- exposure
- > Various binning modes
- > Area of interest modes (AOI)
- > White balance for color versions
- > Micro Four Thirds lens adapter
- > 8/12 Bit video data stream (14 Bit ADC)
- > 256 MB burst mode frame store
- > 4 x Power Output (PWM)
- > Programmable sequencer für shutter and LED illumination
- > SDK für Windows, macOS and Linux
- > GenICam 3.0 standard compliant
- > Integrated multichannel strobe controller

EXO Series

exo183MGETR

Resolution	5496 x 3672 px
Frame rate (max.)	5 fps
Frame rate burst mode (max.)	16 fps
Chroma	mono
Interface	GigE Vision

Sensor

Sensor	IMX183CLK
Manufacturer	Sony
Sensor type	Area CMOS
Shutter type	rolling shutter
Sensor size (h x v)	13.19 x 8.81 mm
Optical diagonal	15.86 mm
Sensor format	1 "
Pixel size (h x v)	2.4 x 2.4 μm

Camera

Exposure modes	MANUAL;AUTO
Trigger modes	INTERNAL;SOFTWARE;EXTERNAL
Exposure time (min)	120 μs
Exposure time (max)	1 sec (external ∞)
Pixel format / max	mono8, mono12packed / 12 bit
Gain modes / max	manual, auto / 18 dB
S/N ratio	40 dB
Dynamic range	71.5 dB
Internal memory	256 MB SDRAM, 32 MB Flash

Feature Set

AOI	yes
LUT	yes
Offset	yes
Readout control	yes
Binning	yes
Image flip	yes

Housing

Lens mount	MFT
Dimensions (w x h x d)	58 x 58 x 44.5 mm
Weight	320 g
Ambient temperature	-10 to 45 °C
Protection class	IP40

I/O-Interfaces

Input up to 24V	2 x
Input OPTO	1 x
Output open drain	4 x
I/O RS-232	1 x
Power supply	10 to 25 V (DC)
Power consumption	7 W (dep. on operating mode)

Dimensions [mm]

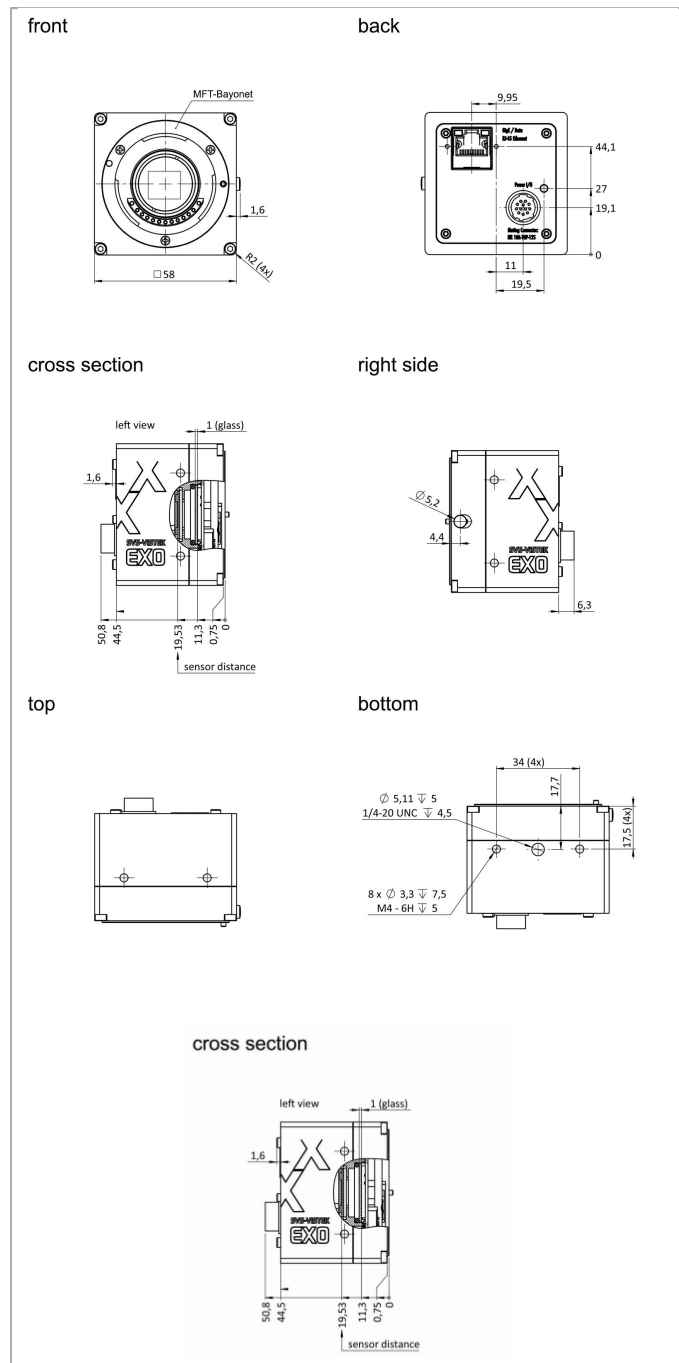

Pinout

