

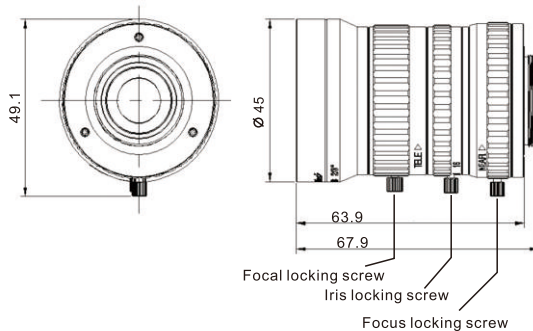

Pomeas 5 Mega Pixels FA/Machine Vision Lens **PMS-1236MC5M**

2/3"	5 Mega	MANUAL	C-mount	METAL
Max. Sensor Size	5 Mega Pixels	Manual Iris	C-mount	Metal Material



Unit : mm

- 1.Support 5 MP 2/3" camera
2. Focus and iris locking screw to ensure stable focusing
3. Low imaging distortion
4. Compact structure,excellent optical performance

Code	PMS-1236MC5M		
Resolution	5 MP;160lp/mm (center) 125lp/mm (corner)		
Focal Length	12-36mm		
Iris Range	F2.8-F16		
Max. Sensor Size	2/3" (8.8mm X 6.6mm ϕ 11mm)		
Field of View (Diagonal x Horizontal x Verticle)	2/3"	50.8°x41.2°x31.2° (wide)	17.2°x13.8°x10.4° (tele)
	1/2"	37.7°x 30.3°x 22.8° (wide)	12.6°x10.1°x 7.6° (tele)
Focusing Range	0.15m- ∞ (wide) 0.45m- ∞ (tele)		
Object Dimensions	163.4mm X 130.7mm X 98.0mm (wide) 152.0mm X 121.6mm X 107.4mm (tele)		
Control	Focus	Manual	
	Iris	Manual	
Distortion	2/3"	-3.4%@y=5.5mm (wide)	1.4%@y=5.5mm (tele)
	1/2"	-2.2%@y=4.0mm (wide)	0.9%@y=4.0mm (tele)
Back Focal Length(in air)	18.93mm (wide) 18.87mm(tele)		
Mount	C-mount		
Filter Thread	M40.5x0.5mm		
Working Temperature	-10°C ~ +50°C		
Weight	188.0g		