



English

VISION:analog™

**29mm Cubic EIA
Analog B/W Camera**

VCC-G20E30B

**Product Specification
& Operational Manual**

CIS Corporation

Table of Contents

1. Scope of Application.....	3
2. Handling Precautions	3
3. Product Outline.....	4
4. Specification.....	5
4.1. General Specification	5
4.2. Camera Input/Output Signal Specification.....	7
4.3. CCD Spectral Response (Representative value).....	8
5. Function Settings.....	8
6. External Connector Pin Assignment	14
7. Timing Chart.....	15
7.1. Horizontal Sync Timing	15
7.2. Vertical Sync Timing (2:1 Interlaced / Field).....	16
7.3. Vertical Sync Timing (2:1 Interlaced / Frame).....	16
8. CCD Optical Axis Accuracy	17
9. Dimensions	18
10. Cases for Indemnity (Limited Warranty).....	19
11. CCD Pixel Defect.....	20
12. Product Support.....	20

1. Scope of Application

This is to describe VCC-G20E30B analog EIA B/W CCD Camera. All specifications contained herein are subject to change without prior notice. Reproduction in whole or in part is prohibited.

2. Handling Precautions

The camera must not be used for any nuclear equipments or aerospace equipments with which mechanical failure or malfunction could result in serious bodily injury or loss of human life. Our warranty does not apply to damages or defects caused by irregular and/or abnormal use of the product.

Please observe all warnings and cautions stated below.

Our warranty does not apply to damages or malfunctions caused by neglecting these precautions.

- Do not use or store the camera in the following extreme conditions:
 - Extremely dusty or humid places.
 - Extremely hot or cold places (operating temperature -5°C to $+45^{\circ}\text{C}$)
 - Close to generators of powerful electromagnetic radiation such as radio or TV transmitters.
 - Places subject to fluorescent light reflections.
 - Places subject to unstable (flickering, etc.) lighting conditions.
 - Places subject to strong vibration.
- Do not apply excessive force or static electricity that could damage the camera.
- Do not shoot direct images that are extremely bright (e.g., light source, sun, etc.), and when camera is not in use, put the lens cap on.
- Follow the instructions in Chapter 6, "External connector pin assignment" for connecting the camera. Improper connection may cause damages not only to the camera but also to the connected devices.
- Confirm the mutual ground potential carefully and then connect the camera to monitors or computers. AC leaks from the connected devices may cause damages or destroy the camera.
- Do not apply excessive voltage. (Use only the specified voltage.) Unstable or improper power supply voltage may cause damages or malfunction of the camera.
- The voltage ripple of camera power DC $+12\text{V} \pm 10\%$ shall be within $\pm 50\text{mV}$. Improper power supply voltage may cause noises on the video signals.

In case of abnormal operation, contact the distributor from whom you purchased the product.

3. Product Outline

VCC-G20E30B is a high-resolution industrial B/W analog camera module utilizing a 1/3 type TV format CCD. 380K pixels CCD image sensor with on-chip micro-lenses realizes high sensitivity and high resolution.

Key Features

- HD/VD sync input or Trigger input are valid.
- 1/100s ~ 1/10,000s , 8 steps shutter speed can be set by rear switch as fixed trigger shutter.
100 μ s ~ 250ms shutter speed can be set by trigger pulse width as pulse width trigger shutter.
- Both EIA normal speed and EIA double speed can be operated.
- Restart Rest mode to enable long time exposure can be set.
- Frame or Field storage can be selectable.
- Only 29mm cubic in size (excluding projection), light weight 45g, and speed makes it a best match for use in embedded systems.

4. Specification

4.1. General Specification

Item	Specification				
Pickup device	Device Type		1/3 type Interline Transfer B/W CCD, Sony ICX408AL		
	Effective Pixel Number		768(H) x 494 (V)		
	Unit Cell Size		6.35 μ m (H) x 7.4 μ m (V)		
	Chip Size		6.59mm (H) x 4.68mm (V)		
Video output frequency	30fps	Pixel Clock	14.318 MHz		
		Horizontal Frequency	15.734 kHz	Pixel Clock	910 CLK
		Vertical Frequency	1/30s 2:1 Interlaced 29.97 Hz		
			Scanning lines 525H		
			1/60s Non Interlaced 59.94 Hz		
		Scanning lines 262.5H			
	60fps	Pixel Clock	28.636 MHz		
		Horizontal Frequency	31.468 kHz	Pixel Clock	910 CLK
		Vertical Frequency	1/60s 2:1 Interlaced 59.94 Hz		
			Scanning lines 525H		
			1/120s Non Interlaced 119.9 Hz		
		Scanning lines 262.5H			
Sync. system	Internal sync & HD/VD external sync (Internal/External recognized automatically)				
Video output standard	Analog VS				
Resolution	570 TV lines				
Sensitivity	F8 400 lx (30fps mode: Shutter speed 1/30s, Gain 0dB, 3200K)				
Minimum illumination	F1.4 1.0 lx (30fps mode: Shutter speed 1/30s, Max Gain, VS 50IRE)				
S/N ratio	56dB				
Dust or stains in optical system	No dust or stain shall be detected on the testing screen with setting the camera aperture at F16.				
Power requirements	DC +12V \pm 10%				
Power consumption	1.5 W typ (max. 1.8W) at DC +12V IN				
Dimension	Refer to overall dimension drawing (Clause 9) 29mm x 29mm x 29mm (excluding projection)				
Mass	Approx. 45 gs				
Lens mount	C mount (Refer to overall dimension drawing)				

Item	Specification		
Optical axis accuracy	Refer to drawing for CCD Optical Axis Accuracy (Clause 8)		
Gain variable range	0~12dB (guaranteed range)		
Gamma	1 (fixed)		
Shutter speed variable range	<Normal Shutter Mode> 30fps mode: OFF(1/30), 1/125, 1/250, 1/500, 1/1000, 1/2000, 1/4000, 1/10000s 60fps mode: OFF(1/60), 1/250, 1/500, 1/1000, 1/2000, 1/4000, 1/8000, 1/20000s <Trigger Shutter Mode> 30fps mode: 1/100, 1/125, 1/250, 1/500, 1/1000, 1/2000, 1/4000, 1/10000s 60fps mode: 1/200, 1/250, 1/500, 1/1000, 1/2000, 1/4000, 1/8000, 1/20000s Pulse Width: 100 μ ~ 250ms		
Shutter Mode	Normal Shutter Mode, Restart/Reset Mode, Fixed Trigger Shutter Mode, Pulse Width Trigger Shutter Mode		
Safety/Quality standards	UL: Conform to UL Standard including materials and others. RoHS: Conform to RoHS CE: Conform to EN55022:2006 (Class B) for Emmission Conform to EN61000-6-2: 2005 for Immunity FCC: To be applied to the following. FCC Class A digital Device This device complies with Part 15 of the FCC Rules. Operation is subject to the following two conditions: (1) this device may not cause harmful interference, and (2) this device must accept any interference received, including interference that may cause undesired operation.		
Durability	Vibration	Acceleration	98 m/s ² (10.0G)
		Frequency	20~200 Hz
		Direction	XYZ 3 directions
		Testing time	120 min for each direction
	Shock	No malfunction shall be occurred with 980m/s ² (100G) for $\pm X$, $\pm Y$, $\pm Z$, 6 directions. (without package)	
Operation environment	Temperature	Operation guaranteed: -5°C~+45°C Performance guaranteed: 0°C~+40°C	
	Humidity	RH 20~80% with no condensation	
Storage environment	Temperature	-25°C ~ +60°C	
	Humidity	RH 20~80% with no condensation	

4.2. Camera Input/Output Signal Specification

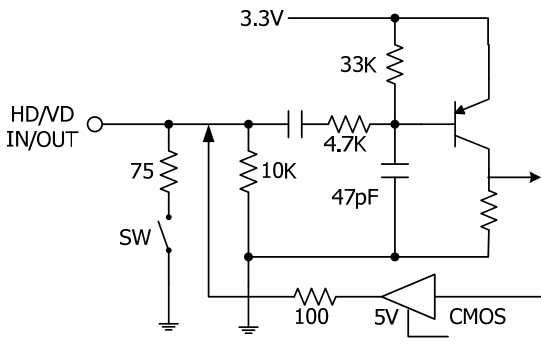
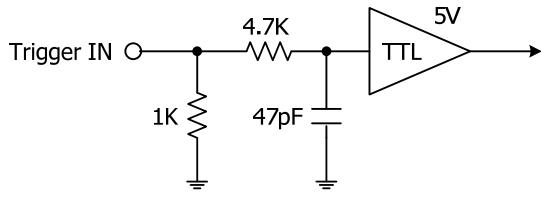
Item	Specification
Video output	Effective output: 752(H) × 485(V) at 2:1 Interlaced scan
Sync signals Input /Output	<p>HD/VD Input signal level: 2~5Vp-p Input impedance: 10kΩ/75Ω Allowable frequency deviation: ±1% Phase difference: HD/VD: under 0±5μs Jitter: under 20ns</p>  <p>WEN output CMOS (74VHC04 equivalent) Output impedance 100Ω HD/VD/WEN output signal level Low 0.5V (max), High 4V (Min)</p>
Trigger input	<p>Polarity: Positive Input signal level: Low 0.5V (max), High 2.5~5V Input impedance: 1kΩ Trigger input width: 4μs ~ 250ms</p> 
Video signal	<p>VS output 1.0V (p-p), Sync. Negative, 75Ω unbalanced, DC connect White clip level: 820 ± 70 mVp-p Setup level: 20 ± 15 mVp-p SYNC level: 290 ± 50 mVp-p</p>

4.3. CCD Spectral Response (Representative value)

※ Lens characteristics and illuminant characteristics are not considered.

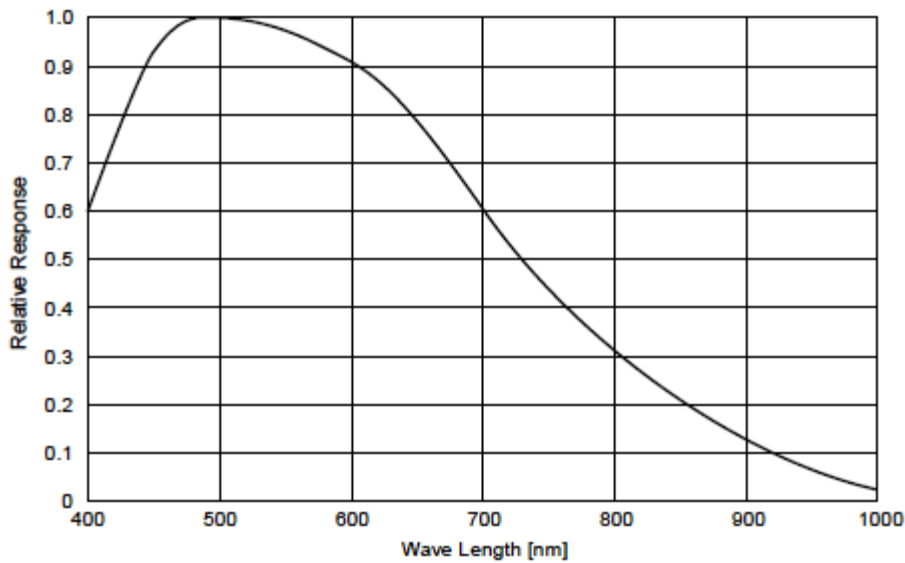

5. Function Settings

1	<input type="radio"/>		ES2	} ◇Shutter Speed: 8 steps At 30fps: OFF(1/30s) ~ 1/10000s At 60fps: OFF(1/60s) ~ 1/20000s
2	<input type="radio"/>		ES1	
3	<input type="radio"/>		ES0	
4	<input type="radio"/>		FLD/FRM	◇Field/Frame
5	<input type="radio"/>		Mode2	◇Shutter Mode
6	<input type="radio"/>		Mode1	Normal Shutter Mode, Restart/Reset Mode, Trigger Shutter Mode
7	<input type="radio"/>		Mode0	
8	<input type="radio"/>		75ohm	◇HD/VD Impedance 10kΩ/75Ω
9	<input type="radio"/>		Speed	◇30fps CLK = 14.318MHz/ 60fps CLK = 28.636MHz
10		<input checked="" type="radio"/>	IN/OUT	◇HD/VD signal input and output setting (No. 6 & 7 pin of 12pins circular connector.)

↑ OFF

● Indicates initial setting position.

Shutter Speed Settings

(At 30fps Mode)

ES2	ES1	ES0	Shutter Speed	Actual Time	
SW1	SW2	SW3		Normal Shutter	Trigger Shutter
OFF	OFF	OFF	OFF (1/30s)	33.4 ms	10.0 ms
OFF	OFF	ON	1/125 s	8.1 ms	8.1 ms
OFF	ON	OFF	1/250 s	4.0 ms	4.0 ms
OFF	ON	ON	1/500 s	2.0 ms	2.0 ms
ON	OFF	OFF	1/1000 s	986 μ s	982 μ s
ON	OFF	ON	1/2000 s	478 μ s	478 μ s
ON	ON	OFF	1/4000 s	225 μ s	225 μ s
ON	ON	ON	1/10000 s	98 μ s	98 μ s

(At 60fps Mode)

ES2	ES1	ES0	Shutter Speed	Actual Time	
SW1	SW2	SW3		Normal Shutter	Trigger Shutter
OFF	OFF	OFF	OFF (1/60s)	16.7 ms	5.0 ms
OFF	OFF	ON	1/250 s	4.0 ms	4.0 ms
OFF	ON	OFF	1/500 s	2.0 ms	2.0 ms
OFF	ON	ON	1/1000 s	1.0 ms	1.0 ms
ON	OFF	OFF	1/2000 s	493 μ s	494 μ s
ON	OFF	ON	1/4000 s	239 μ s	240 μ s
ON	ON	OFF	1/8000 s	113 μ s	113 μ s
ON	ON	ON	1/20000 s	49 μ s	49 μ s

■ Indicates initial setting position

CCD Charge Storage Mode Settings

SW4	OFF	FLD	Field Storage
	ON	FRM	Frame Storage

■ Indicates initial setting position

Shutter Mode Settings

Mode2	Mode1	Mode0	Setting Mode
SW5	SW6	SW7	
OFF	OFF	OFF	Normal Shutter Mode
OFF	ON	ON	Restart/Reset Mode
ON	OFF	OFF	Fixed Trigger Shutter Mode (SYNC Reset Mode)
ON	OFF	ON	" (SYNC Non Reset Mode)
ON	ON	OFF	Pulse Width Trigger Shutter Mode (SYNC Reset Mode)
ON	ON	ON	" (SYNC Non Reset Mode)

■ Indicates initial setting position

Table of Settings

Operation Mode Function	Normal Shutter Mode	Restart/Reset Mode	Fixed Trigger Shutter Mode	Pulse Width Trigger Shutter Mode
2:1 Interlaced	○	○	× (One side field)	× (One side field)
Field/Frame	○	○	○	○
Shutter Speed Settings by rear switch	○	×	○	○
Shutter Speed Settings by trigger pulse width	×	×	○	○
HD/VD Input	○	○	○	○
HD/VD Output	○	×	○	○

Normal Shutter Mode

At normal shutter mode, consecutive video signals are read with EIA compliant 2:1 interlaced scanning. With shutter function, rapidly moving objects can be captured clearly. When adding external sync input, please follow the HD/VD input conditions shown below for 30fps mode.

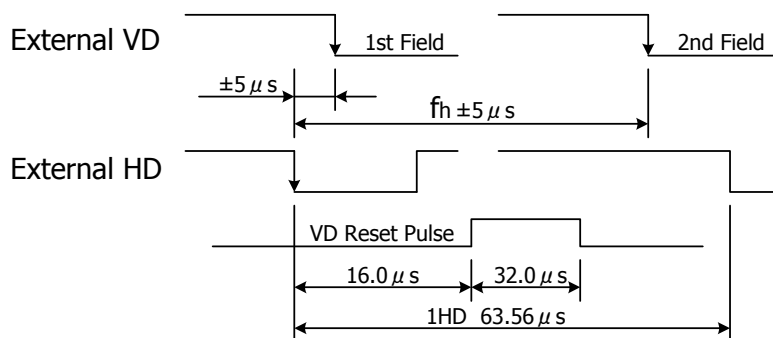

Restart-Reset Mode

With adding EXT VD at random timing with over 1VD, data for one screen image is read out. This function is useful when sensitivity with regular exposure time is not sufficient or when indicating the locus of moving object. ODD/EVEN field is determined by EXT HD/VD phase.

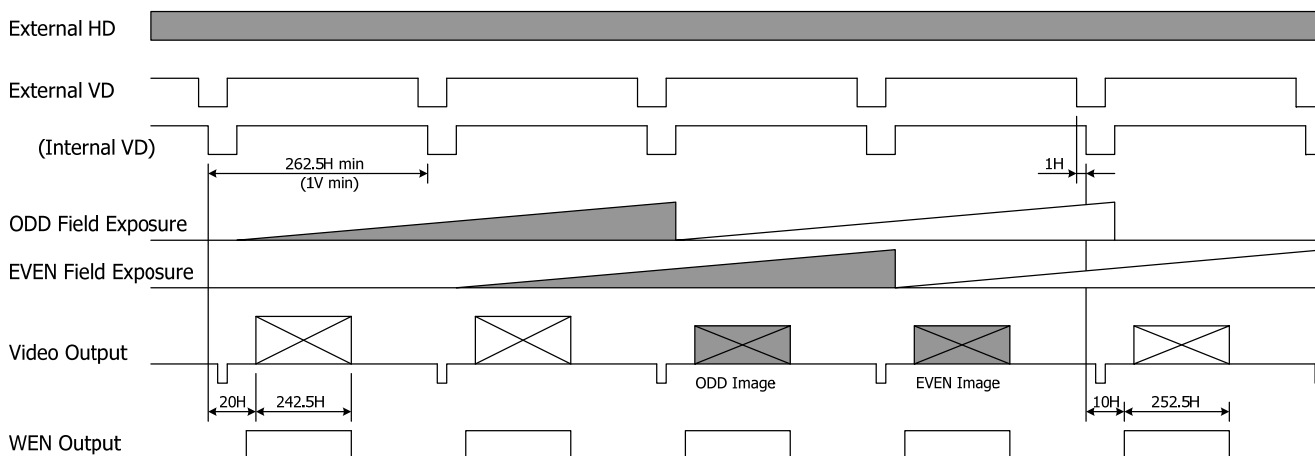

Fixed Trigger Shutter Mode

Exposure time shall be the value set by the rear switch.

In case of SYNC Reset mode

Internal VD is reset after completion of exposure and video output signals are read out after 1 ~ 2H. Internal VD, Composite Sync, and WEN signals are one-to-one correspondence to trigger input so that capturing images can be done with any output signals.

HD/VD sync signals are not necessary basically, but signals can be synchronized with internal HD with inputting HD signals externally.

Exposure time = when setting with switch SW 1 ~4: 1/100 ~ 1/10000s at 30fps.
 1/200 ~ 1/20000s at 60fps.

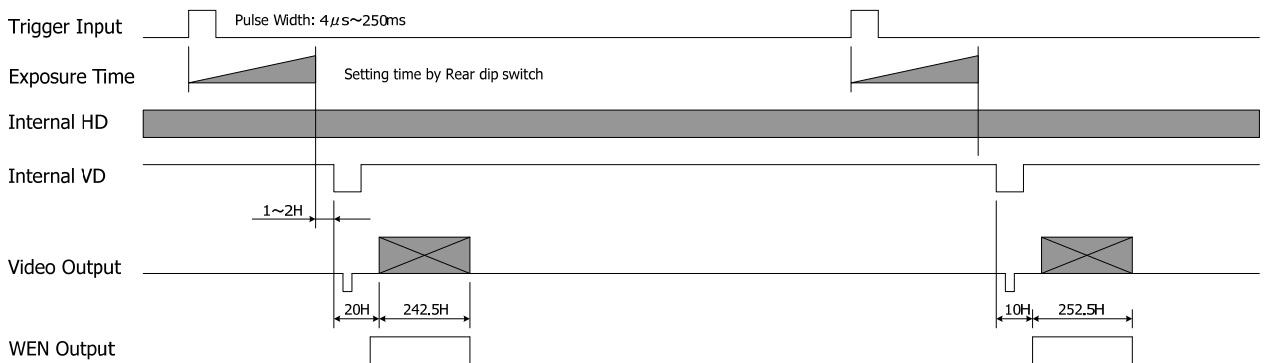

In case of SYNC Non-Reset mode

Video output signals are read out at the first VD position generated after completion of exposure. Single VD should be input between 10 μs ~ 65ms after completion of exposure. External VD input, Composite Sync, and WEN signals are one-to-one correspondence so that any signals can be used to capture images.

Exposure time = when setting with switch SW 1 ~4: 1/100 ~ 1/10000s at 30fps.
 1/200 ~ 1/20000s at 60fps.

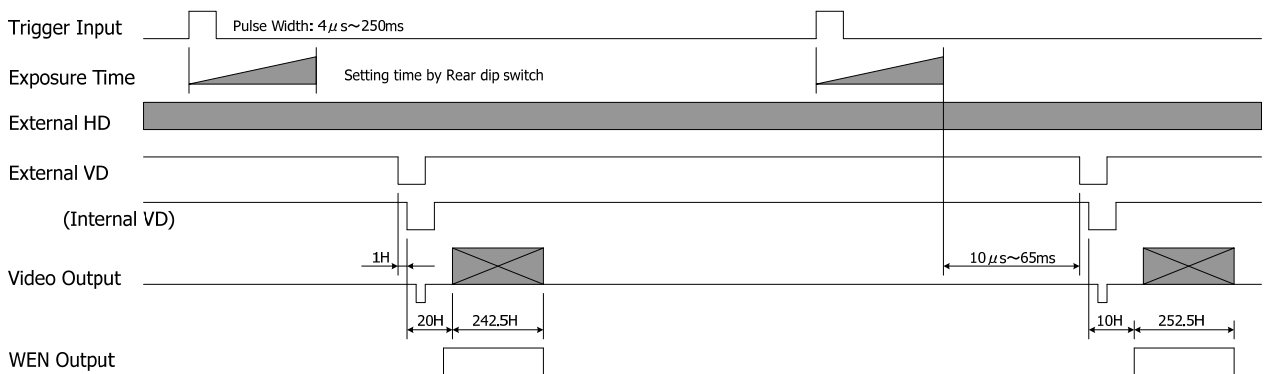

Pulse Width Trigger Shutter Mode

Exposure time shall be the value set by the trigger pulse width.

In case of SYNC Reset mode

Internal VD is reset after completion of exposure and video output signals are read out after 1 ~ 2H. Internal VD, Composite Sync, and WEN signals are one-to-one correspondence to trigger input so that capturing images can be done with any output signals.

HD/VD sync signals are not necessary basically, but signals can be synchronized with internal HD with inputting HD signals externally.

Exposure time = Trigger Pulse Width (μs) + 96 μs at 30fps.

Trigger Pulse Width (μs) + 48 μs at 60fps.

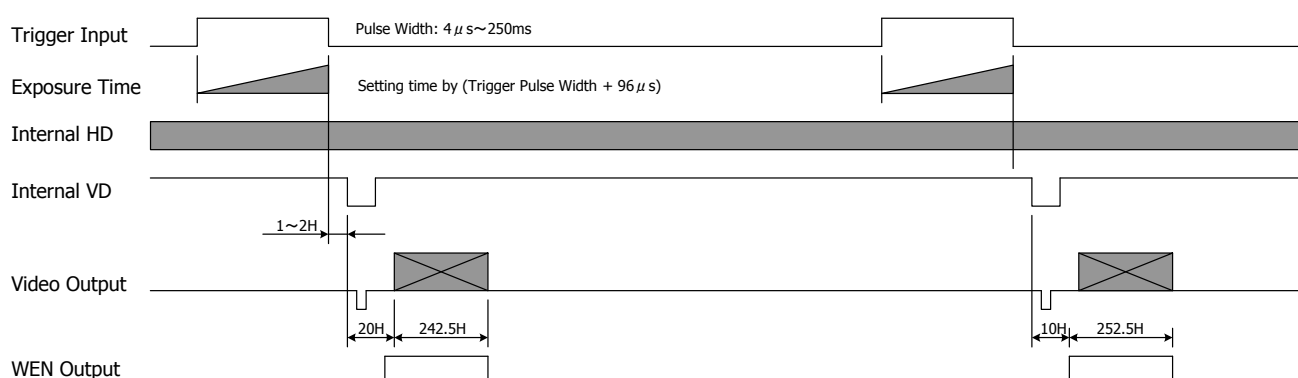

In case of SYNC Non-Reset mode

Video output signals are read out at the first VD position generated after completion of exposure.

Single VD should be input between 10 μs ~ 65ms after completion of exposure.

External VD input, Composite Sync, and WEN signals are one-to-one correspondence so that any signals can be used to capture images.

Exposure time = Trigger Pulse Width (μs) + 96 μs at 30fps.

Trigger Pulse Width (μs) + 48 μs at 60fps.

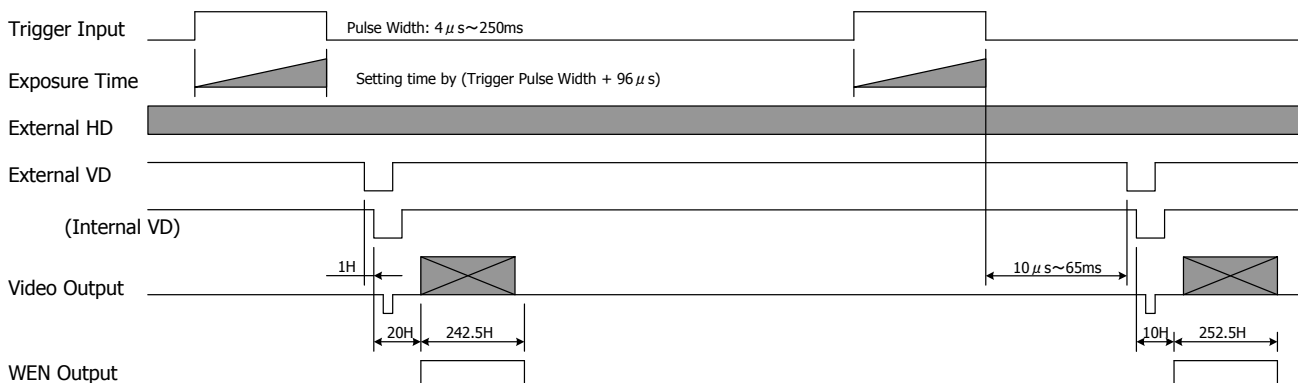

Cautions for Trigger Shutter Modes

Caution 1: When the next trigger is input before the completion of video signals output for the prior trigger, the images could be improper.

Caution 2: Smear or blooming could occur when strong incident light is extensively illuminated, with setting the electric shutter at high speed. To avoid this smear or blooming, lower the volume of incident light or use a stroboscopic light source to control the light volume.

Caution 3: Please refer to the exposure timing chart below for 30fps mode for the actual timing to start exposure after adding trigger input, and or for the actual timing to complete exposure at pulse width trigger shutter operation.

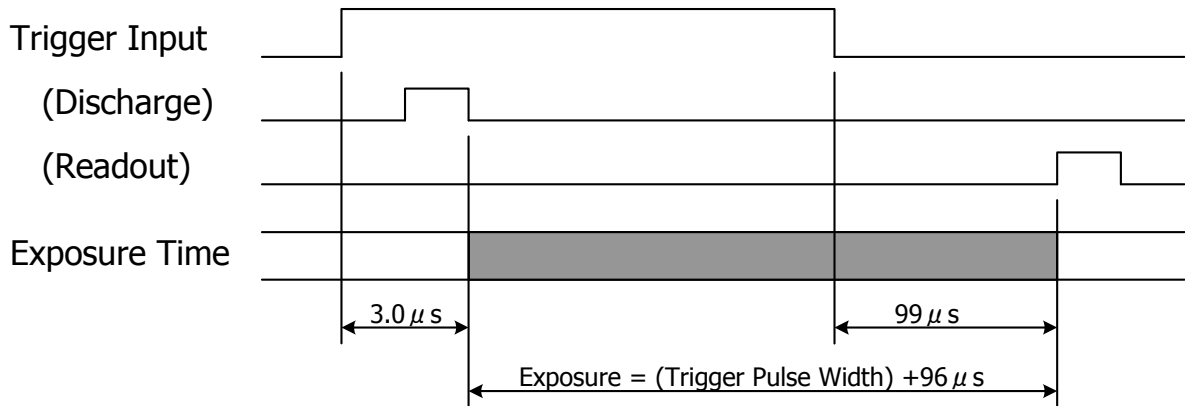

HD/VD Input Impedance Selection

SW8 OFF HD/VD Input Impedance 10kΩ
 ON HD/VD Input Impedance 75Ω

Frame Rate Speed Selection

SW9 OFF 30fps Mode CLK= 14.318MHz
 ON 60fps Mode CLK= 28.636MHz

When changing pixel clock, please reboot the camera power.

HD/VD Input and Output Selection

SW10 OFF HD/VD Output
 ON HD/VD Input
 (Internal/External Sync can be recognized automatically.)
 Indicates initial setting position

6. External Connector Pin Assignment

12 pins Circular Connector SNH-10-12(RPCB) (SAMWOO)

Pin No.	
1	GND
2	Power In DC+12V
3	GND
4	Video Out
5	GND
6	HD In/Out
7	VD In/Out
8	GND
9	N/A
10	WEN Out
11	Trig In
12	GND

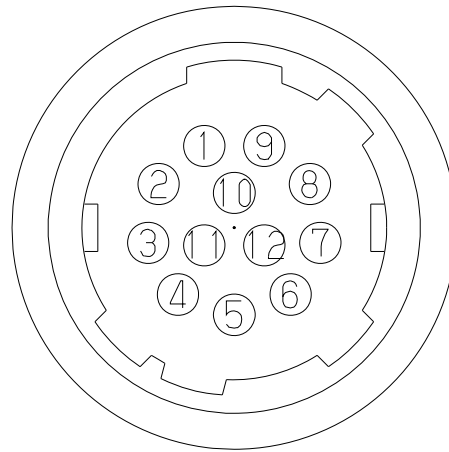

7. Timing Chart

7.1. Horizontal Sync Timing

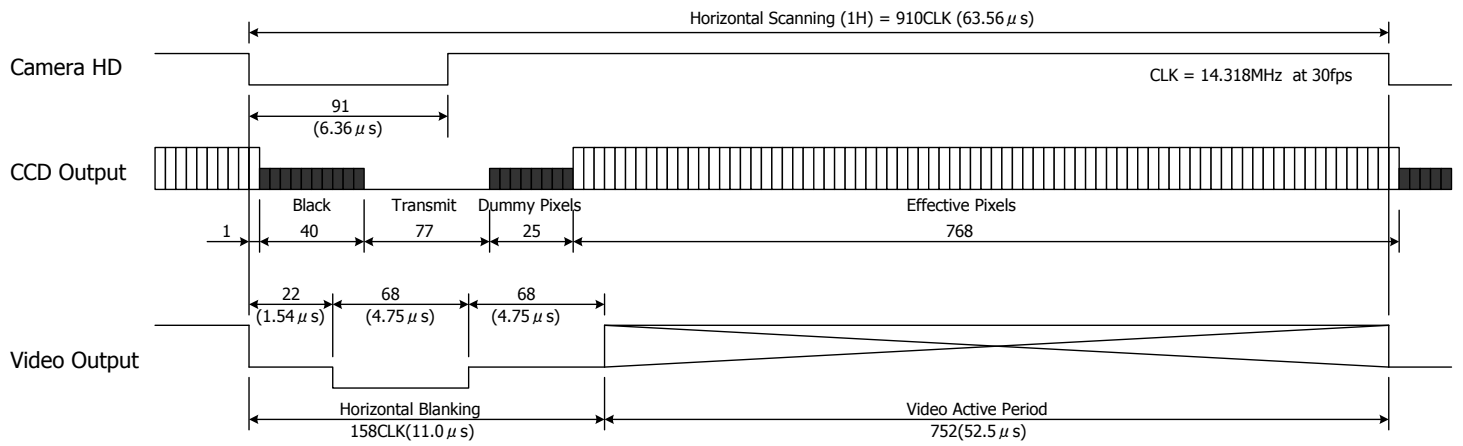

7.2. Vertical Sync Timing (Field Storage)

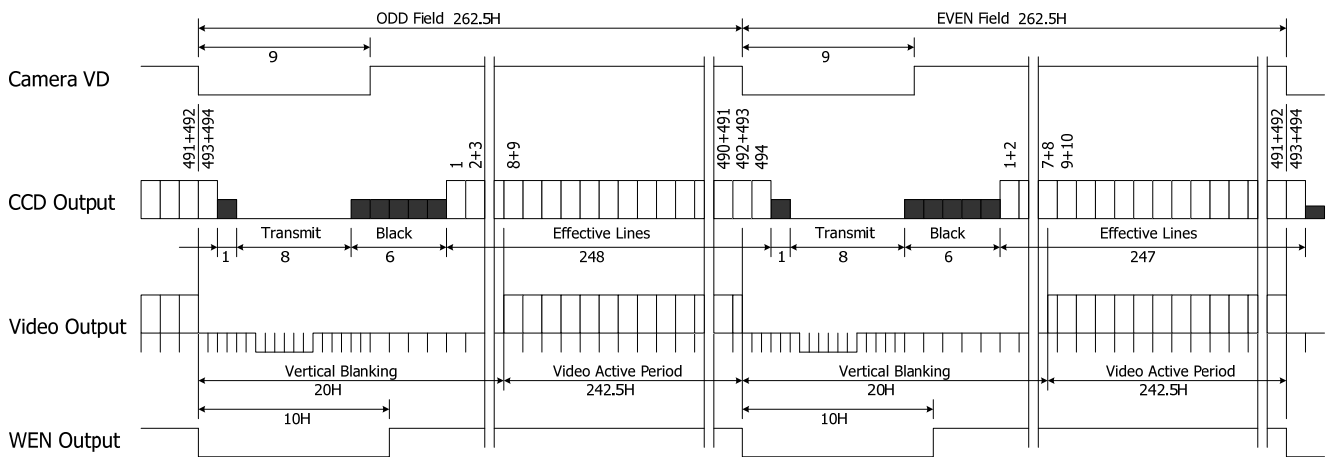

7.3. Vertical Sync Timing (Frame Storage)

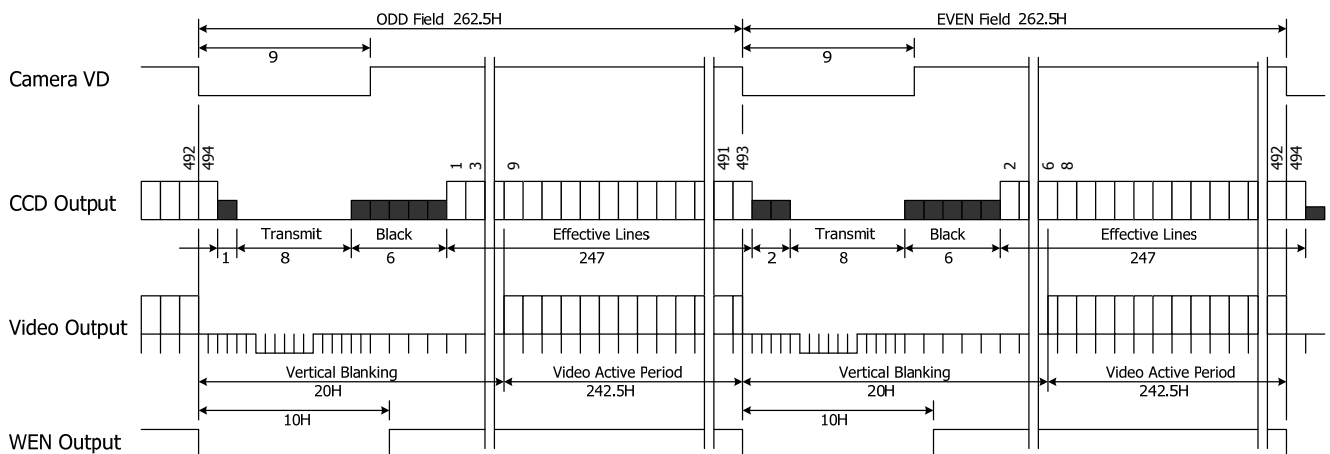

8. CCD Optical Axis Accuracy

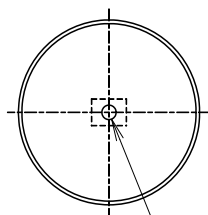
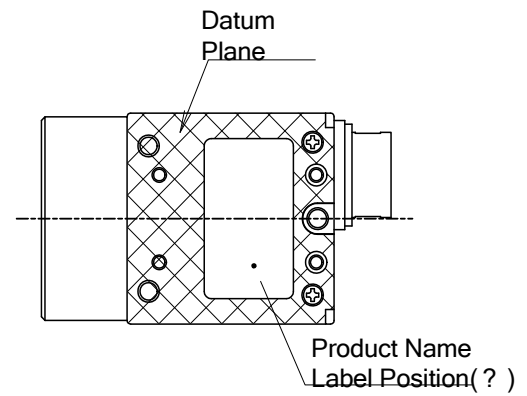
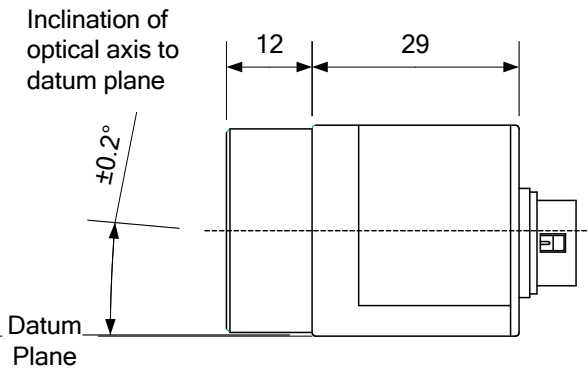
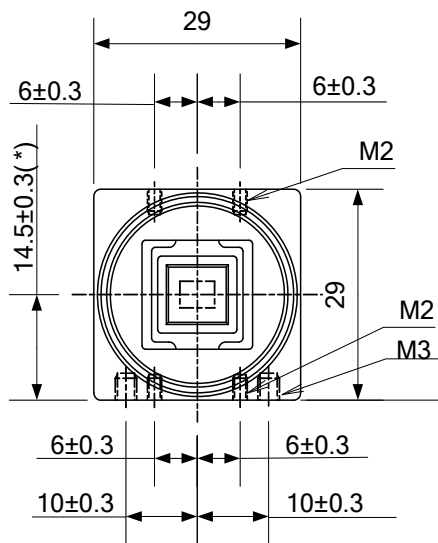

The center of effective pixels shall be within $f 0.6$ to the center of lens mount.

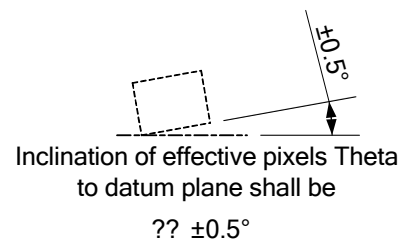

(*) Dimension from datum plane to the center of lens mount.

910-015-00-00
(Unit : mm)

9. Dimensions

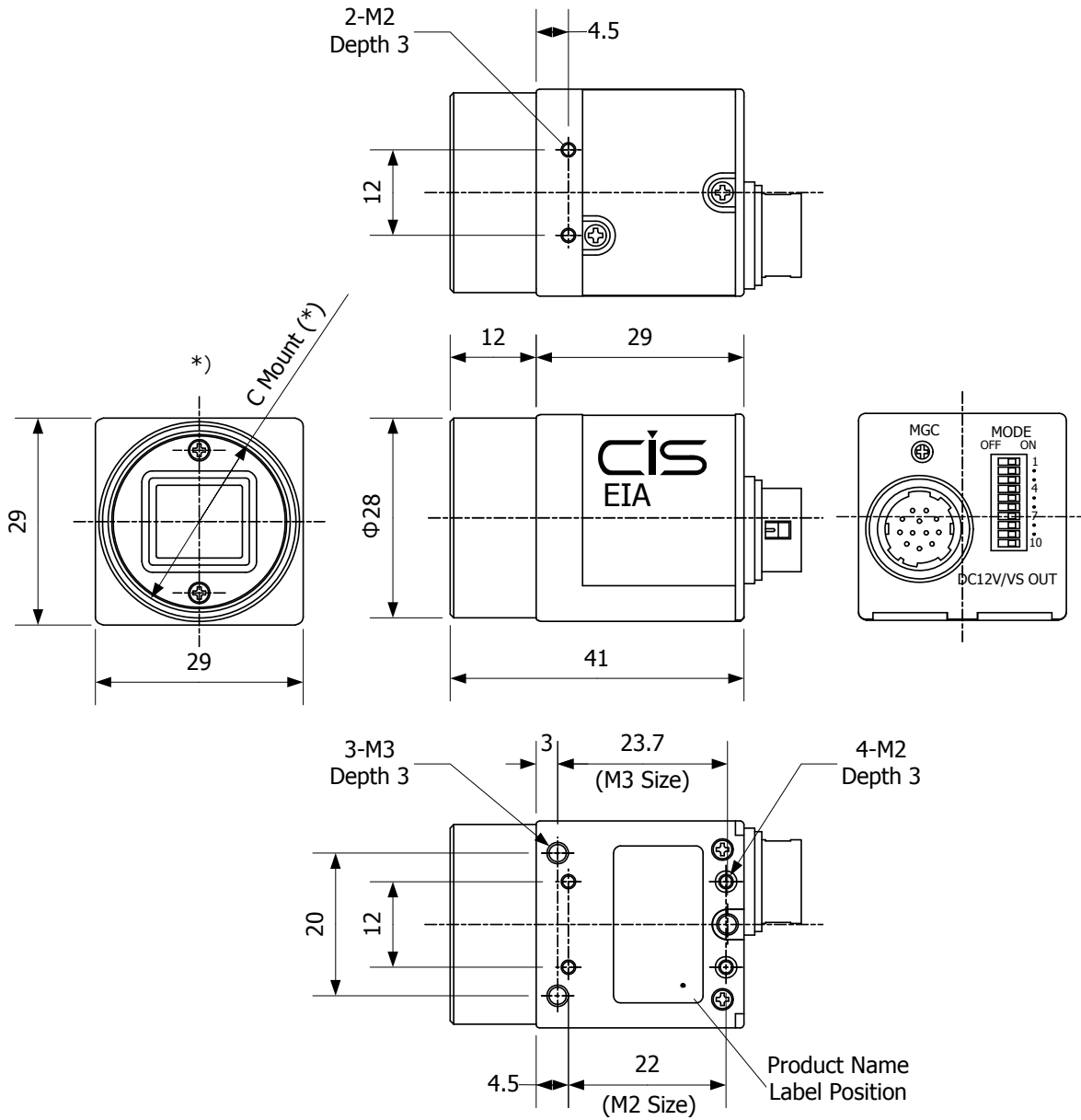

*) C Mount screws comply with ANSI/ASME B1.1, 1-32UN(2B).
 *) Screw length from C mount lens surface shall be under 6mm.
 And protruding portion shall be less than 10mm.

999-532-00-00

(Unit:mm)

10. Cases for Indemnity (Limited Warranty)

We shall be exempted from taking responsibility and held harmless for damage or losses incurred by the user in the following cases.

- ✧ In case damage or losses are caused by fire, earthquake, or other acts of God, acts by third party, deliberate or accidental misuse by the user, or use under extreme operating conditions.
- ✧ In case indirect, additional, consequential damages (loss of business interests, suspension of business activities) are incurred as result of malfunction or non-function of the equipment, we shall be exempted from responsibility for such damages.
- ✧ In case damage or losses are caused by failure to observe the information contained in the instructions in this product specification & operation manual.
- ✧ In case damage or losses are caused by use contrary to the instructions in this product specification & operation manual.
- ✧ In case damage or losses are caused by malfunction or other problems resulting from use of equipment or software that is not specified.
- ✧ In case damage or losses are caused by repair or modification conducted by the customer or any unauthorized third party (such as an unauthorized service representative).
- ✧ Expenses we bear on this product shall be limited to the individual price of the product.

11. CCD Pixel Defect

After delivery, CCD pixel defects might be noted with time of usage of the products.

The cause of the CCD pixel defects is the characteristic phenomenon of CCD itself and CIS shall be exempted from taking responsibility on it.

12. Product Support

When defects or malfunction of our products occur, and if you would like us to investigate on the cause and repair, please contact your distributors you purchased from to consult and coordinate.