

XCL-5005 (B/W) XCL-5005CR (Color)

CL Output	2/3 Type CCD	Progressive Scan	Square Pixels	C Lens Mount	5 MEGA Output	Partial Scan	Long Exposure
Normal Shutter	External Trigger Shutter	One-Push White Balance	Fixed White Balance	Manual White Balance	Image Filter	LUT	RS232C Control
B/W	RGB RAW						

*1 : XCL-5005CR
*2 : XCL-5005

Connection Diagram P45



Outline

The XCL-5005 series cameras incorporate a 5-megapixel 2/3-type CCD that produces detailed images. The XCL-5005 is a monochrome camera, while the XCL-5005CR outputs 24-bit RGB or RAW color data that enables true color reproduction. Both models are compatible with the Mini Camera Link standard (non-PoCL/PoCL*), are equipped with 12-pin connectors, and feature a selectable power supply (12-pin power supply has priority). The cameras are equipped with new functions such as selectable image output for various bit lengths, as well as hardware-based pre-processing functions and partial scan function, which are found only on digital cameras. High resistance to shock and vibration makes these camera modules ideal for machine vision and other applications that require high-definition image reproduction.

*PoCL (Power over Camera Link)

Dimensions

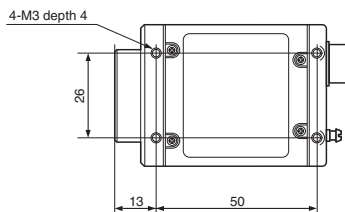
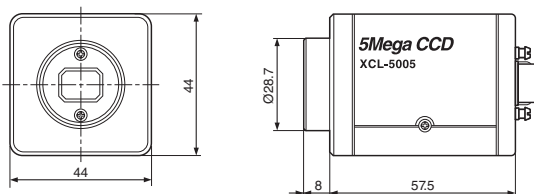
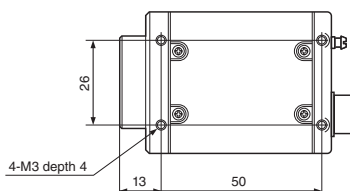

Unit: mm

Features

XCL-5005 series

- 2/3-type 5 Mega pixel CCD
- Effective lines: 2,448 (H) × 2,050 (V)
- Frame rate: 15 fps
- Partial scan function (Vertical random read scan)
- Shutter: Normal /External trigger shutter
- High Shock and Vibration Resistance
- RS-232C Control
- CameraLink: non-PoCL/PoCL
- Switching an Output tap (1TAP/2TAP)
- Various mode setting
 - Shutter speed
 - Gamma
 - Partial scan

XCL-5005

- Read mode: Normal/Binning
- Outline detection, Outline Emphasis
- Binarization
- 3×3 image filter
- Flip-Flop

XCL-5005CR

- One-push white balance function
- Switching color output (RAW color or RGB)
- Color Bar Chart

Digital output CameraLink Base Configuration

	1tap	2tap
XCL-5005	8/10/12 bit 80 MHz	8/10/12 bit 40 MHz
XCL-5005CR	8/10/12 bit 80 MHz 24 bit RGB 80 MHz	8/10/12 bit 40 MHz

Accessories

- Compact camera adaptor
 - DC-700/700CE
- 12-pin camera cable (CE standard)
 - CCXC-12P02N (2 m)
 - CCXC-12P05N (5 m)
 - CCXC-12P10N (10 m)
 - CCXC-12P25N (25 m)
- Tripod adaptor
 - VCT-ST70I

Spectral Sensitivity Characteristics

• XCL-5005

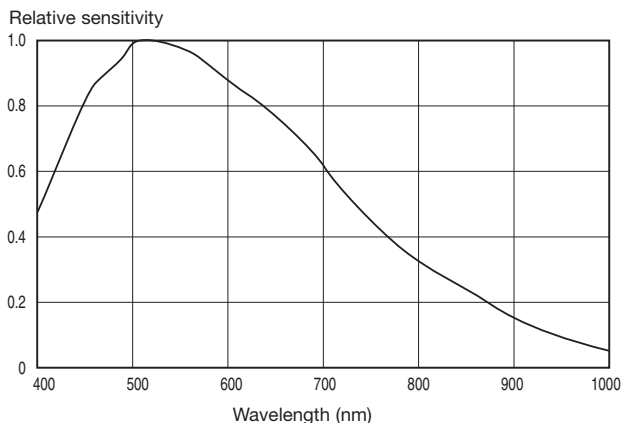

(Lens characteristics and light source characteristics excluded.)

• XCL-5005CR

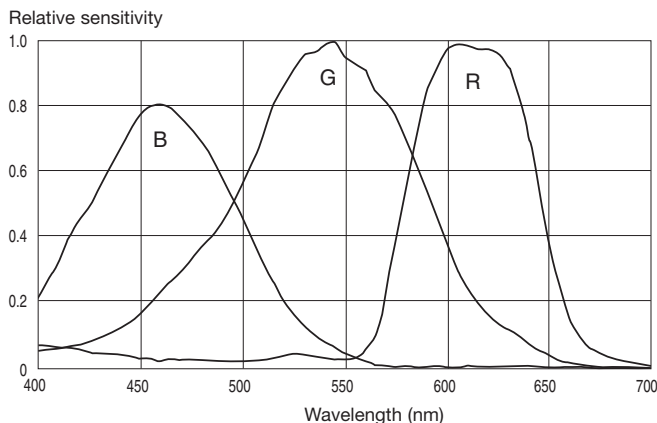

(Lens characteristics and light source characteristics excluded.)

Specifications

	XCL-5005	XCL-5005CR
Camera		
Image type	B/W	Color
Image sensor	2/3-type Progressive Scan IT transfer CCD	
Number of effective pixels (H) × (V)	2,456 × 2,058	
Cell size (H) × (V)	3.45 μm × 3.45 μm	
Standard output pixels (H) × (V)	2,448 × 2,048	
Color filter	—	Color moxaic
Frame rate	15 fps	
Minimum illumination	1 lx (Iris: F1.4, Gain: 18 dB, Shutter: 1/15 s)	8 lx (Iris: F1.4, Gain: 18 dB, Shutter: 1/15 s)
Sensitivity	F5.6 (400 lx, Gain: 0 dB)	F5.6 (2000 lx, Gain: 0 dB)
SNR	1 step (Lens close, Gain: 0 dB, 8 bits)	
Gain	Auto, Manual: 0 dB to 18 dB	
Shutter speed (Normal)	2 sec to 1/10,000 sec	
White balance	—	Preset, Manual, One Push, AWB
Reference video output level	3,760 steps (12 bits)	
Reference pedestal level	240 steps (12 bits)	
Output signal frequency	15 Hz (Normal mode)	
Camera Features		
Readout modes	Normal, Binning (1 × 2), Partial scan	Normal, Partial scan
Readout features	Binarization, Gamma (arbitrary setting), 3 × 3 filter, Gray scale	Gamma (arbitrary setting), Color bar feature
Synchronization	Hardware trigger	
Trigger modes	Edge Detection, Exposure time setting by trigger width	
Partial scan	OFF/ON (Starting Position: per 5 lines, Area: per line)	OFF/ON (Starting Position: per 10 lines, Area: per 2 lines)
Signal output (only DC IN terminal)	DVAL/EXPOSURE/GND/(selectable, default setting GND)	
Detail	○	—
Interface		
Image output	12, 10, 8-bit (default setting 12 bit), digital	12, 10, 8-bit (default setting Raw 12 bit), Raw, digital, RGB Color
Digital interface	LVDS	
Camera specification	non-PoCL/PoCL, Base Cofiguration, CameraLink® Version 1.2	
Output data clock	80 MHz (1 tap) 40 MHz (2 tap)	80 MHz (1 tap) 40 MHz (2 tap, only Raw Color)
General		
Lens mount	C-mount	
Flange focal length	17.526 mm	
Power requirements	DC +12 V (10.0 V to 15.0 V)	
Power consumption	3.8 W	
Operating temperature	-5°C to +45°C	
Performance quarantee temperature	0°C to 40°C	
Storage temperature	-30°C to +60°C	
Operating humidity	20% to 80% (no condensation)	
Storage humidity	20% to 95% (no condensation)	
Vibration resistance	10 G (20 Hz to 200 Hz)	
Shock resistance	70 G	
Dimensions (W × H × D)	44 × 44 × 57.5 mm (not including projecting parts)	
Mass	130 g	
MTBF	75,300 hours (Approx. 8.6 years)	
Regulations	UL60950-1+CSA C22.2 No.60950.1, FCC/ICES-003: Class A, CE: EN61326, AS/NZ: EN61326, VCCI Class A, KC: KN22/KN24: Class A	
Supplied accessories	Lens mount cap (1), Operating Instructions (1)	

Location and Function of Parts and Controls

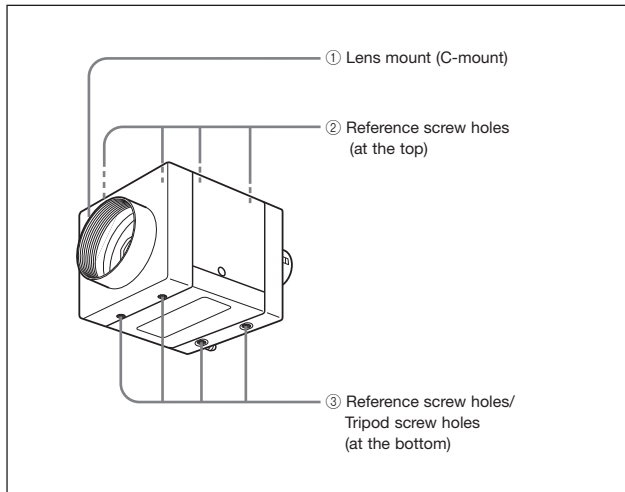

① Lens mount (C-mount)

Attach any C-mount lens or other optical equipment.

Note

The lens must not project more than 10 mm from the lens mount.

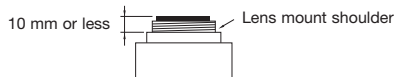

② Reference screw holes (at the top)

③ Reference screw holes/Tripod screw holes (at the bottom)

These precision screw holes are for locking the camera module. Locking the camera module into these holes secures the optical axis alignment. You can install the camera on a tripod. To install on a tripod, you will need to install a tripod adaptor VCT-ST70I to the camera on the reference holes. 10 mm or less Lens mount shoulder.

Rear Panel

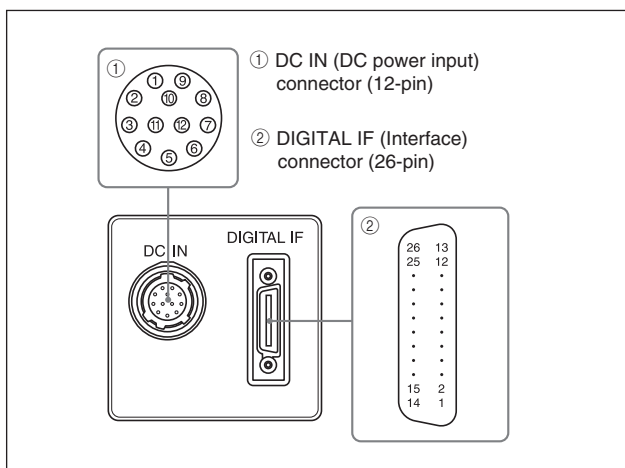

① DC IN (DC power input) connector (12-pin)

You can connect a CCXC-12P05N camera cable to input the +12 V DC power supply. If you use a camera module interface board with support for PoCL, you can operate the camera without using this connector. The pin configuration of this connector is as follows.

② DIGITAL IF (Interface) connector (26-pin)

You can connect a CameraLink cable to this connector to control a camera module from a host device utilizing the serial communication protocol while outputting a video signal from the camera module. If you use a camera module interface board with support for PoCL, you can also supply power from this connector. You can input the external trigger signal via the 26-pin connector and operate a camera module in the external trigger mode. The pin configuration of this connector is as follows.

Note

When you operating a camera module by inputting an external trigger signal via the 26-pin connector, make sure to input external trigger signal that meet the following specifications to both the two pins.

Connector Pin Assignments

DC IN (DC Power input) 12-pin connector

Pin No.	Signal	Pin No.	Signal
1	Ground	7	NC
2	+12 V DC	8	Ground
3	Ground	9	NC
4	NC	10	Signal* output
5	Ground	11	Trigger pulse input
6	NC	12	Ground

* Signal output from the Tenth pin of 12 pins connector.

You can select one of the following signals according to the setting.

Ground/DVAL output/Exposure pules output.

The default setting in the factory is Ground.

DIGITAL IF (Interface) connector (26-pin)

Camera Link Base Configuration: 1tap

Pin No.	Digital signal	Pin No.	Digital signal
1	Power supply or Ground*	14	INNER_SHIELD (Ground)
2	X0- output (Signal)	15	X0+ output (Signal)
3	X1- output (Signal)	16	X1+ output (Signal)
4	X2- output (Signal)	17	X2+ output (Signal)
5	XCLK- output (Signal)	18	XCLK+ output (Signal)
6	X3- output (Signal)	19	X3+ output (Signal)
7	Ser TC+ (Signal)	20	Ser TC- (Signal)
8	Ser TFG- (Signal)	21	Ser TFG+ (Signal)
9	TRIG- input (Signal)	22	TRIG+ input (Signal)
10	NC	23	NC
11	NC	24	NC
12	NC	25	NC
13	INNER_SHIELD (Ground)	26	Power supply or Ground*

* The connection differs depending on the type of camera module interface board you use.

In the case of PoCL support: Both the 1 st pin and 26 th pin are POWER (Power supply)

In the case of non-PoCL support: Both the 1 st pin and 26 th pin are INNER_SHELD (Ground)

Controlling the Camera From the Host Device

You can control the camera from host device such as a PC. The following table shows the control functions.

Control functions		XCL-5005	XCL-5005CR
Operating mode		Normal/Trigger	
Shutter speed	Normal	2 sec to 1/10000 sec	
	Edge	2 sec to 1/10000 sec	
	Trigger pulse width	Setting by trigger pulse width	
Gain		0 dB to 18 dB	
Binning		OFF/ON	—
Partial scan		OFF/ON	
Edge detection, Edge emphasis		OFF/ON	—
Binarization		OFF/ON	—
Gamma control		OFF/ON (mode1 to mode 7)	
3 x 3 Image filtering		OFF/ON	—
Video output switch		12 bits/10 bits/8 bits	
External trigger input		26 pin connector/12 pin connector	
Switch output tap		1 Tap/2 Tap	
White balance		—	Preset/Manual/One push (auto)
Switch color output		—	RAW data/RGB 24 bits

Note

Make sure to supply power to the camera module and confirm that the camera module is operating before inputting a trigger signal. If you input external signals to a camera module without the power supplied, this may cause a malfunction of the camera module.

Trigger Signal Specifications

DC IN terminal

(When positive pole is set)

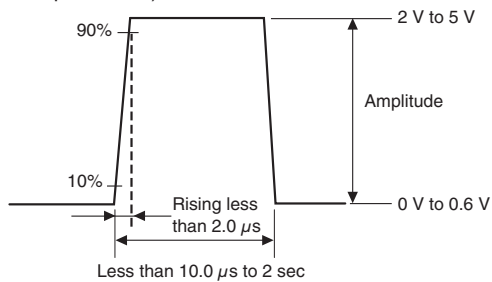

Input Impedance: Stated in the voltage determined at more than 10 kΩ.

(When negative pole is set)

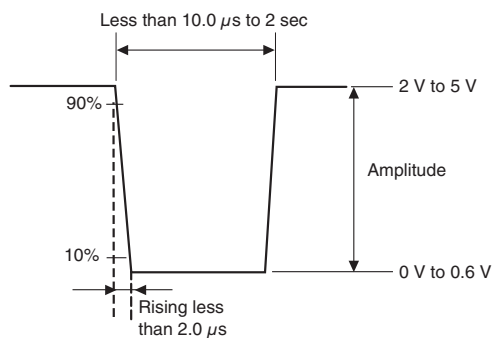

Input Impedance: Stated in the voltage determined at more than 10 kΩ.

DIGITAL IF terminal

Convert the signal which meets the specifications above into LVDS format (3.3 V power drive IC output), and inputs the converted signal.

Specification for the External Trigger Signal

Amplitude : LVDS using 3.3 volt IC

Connections : Input a TRIG (-) signal to the 9th pin

: Input a TRIG (+) signal to the 22nd pin

Note that the signal level cannot be recognized correctly by the camera if it does not meet the following conditions.

H level: 1.5 V to 1.7 V

L level: 0.8 V to 1.0 V

Polarity: positive



DVAL/Exposure Output Specific (only DC IN terminal)

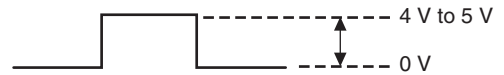

Stated in the voltage of when terminating at more than 10 kΩ.

Connecting the Cables

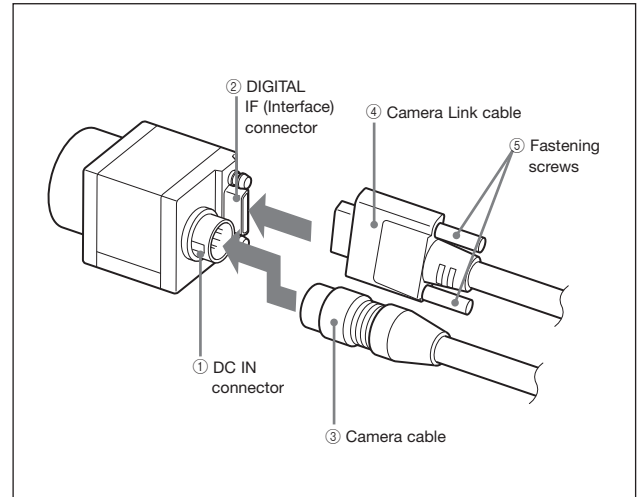

- ① DC IN Connector
- ② DIGITAL IF (Interface) Connector
- ③ Camera Cable
- ④ Camera Link Cable
- ⑤ Fastening Screws

Connect the Camera cable to the DC IN connector and the Camera Link cable to the digital Interface cable respectively. If you use a camera module interface board with support for PoCL, you can operate the camera even it connect the Camera Link cable, turn the two fastening screws on the connector to secure the cable tightly. Connect the other end of the Camera cable to the DC-700/700CE and the other end of the Camera Link cable to the camera module interface board.