

XC-HR50 XC-HR57

Non-TV Output	Progressive Scan	^{*1} 1/3 Type CCD	^{*2} 1/2 Type CCD	Square Pixels	C Lens Mount	VS Output
VGA Output	1/60 Sec 1K Non-Interface	Partial Scan	HD/VD External Sync	Restart Reset	Long Exposure	Normal Shutter
Mode 1 (Non-Reset Mode) External Trigger Shutter	Mode 2 (Non-Reset Mode) External Trigger Shutter					

*1 :XC-HR50
*2 :XC-HR57

Connection Diagram P76



Outline

The XC-HR50 and XC-HR57 are monochrome camera modules with full pixel read-out. The XC-HR50 incorporates a 1/3 type double scan CCD, and the XC-HR57 incorporates a 1/2 type double scan CCD. Both cameras have VGA resolution (648 (H) × 494 (V)) output at 60 frames/sec, making them ideal for high-speed image capturing. Relying on high-density mounting technology, these cameras are the same size as other Sony cameras in the XC-HR series and XC-E series, which increases their mechanical compatibility. These compact (29 (W) × 29 (H) × 30 (D) mm) double-speed progressive scan cameras are also lightweight and have a short tact time.

Features

- XC-HR50: 1/3-type PS CCD
XC-HR57: 1/2-type PS CCD
 - Double Scan CCD
 - The CCD has square pixels eliminating the need for aspect ratio conversion.
 - VGA resolution (648 × 494 pixels) image capturing at a speed of 60 fps.
- Partial scanning (at restart/reset ON, Binning OFF) Up to 240 fps. (Effective line: 102 lines)
- Compact and lightweight
29 (W) × 29 (H) × 30 (D) mm, Approx. 50 g
- External trigger shutter 1/4 sec to 1/100,000 sec
- Electronic Shutter 1/100 sec to 1/20,000 sec
- Synchronization Internal/External (HD/VD)
- C-mount system
- High shock and vibration tolerant

Accessories

- Compact camera adaptor
 - DC-700/700CE
- 12-pin camera cable (CE standard)
 - CCXC-12P02N (2 m)
 - CCXC-12P05N (5 m)
 - CCXC-12P10N (10 m)
 - CCXC-12P25N (25 m)
- Tripod adaptor
 - VCT-333I

Dimensions

Camera body of all XC-HR models

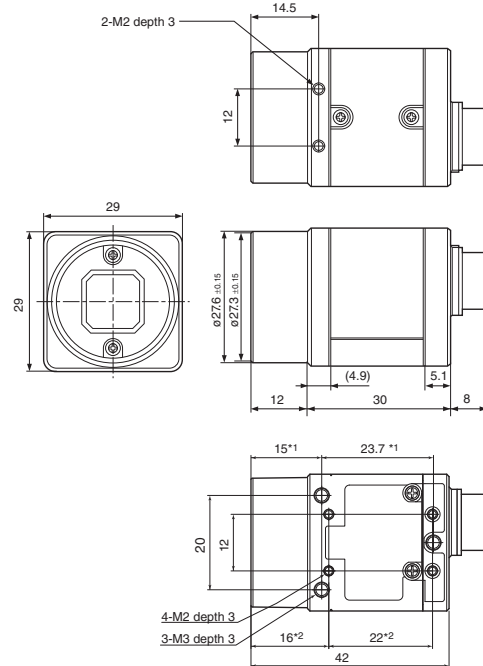

*1: for 3-M3 screw
*2: for 4-M2 screw

Unit: mm

Spectral Sensitivity Characteristics

• XC-HR50/HR57 (Typical Values)

Relative sensitivity

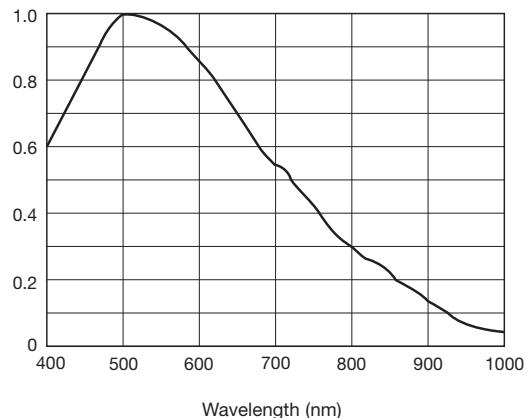

(Lens characteristics and light source characteristics excluded.)

Location and Function of Parts and Controls

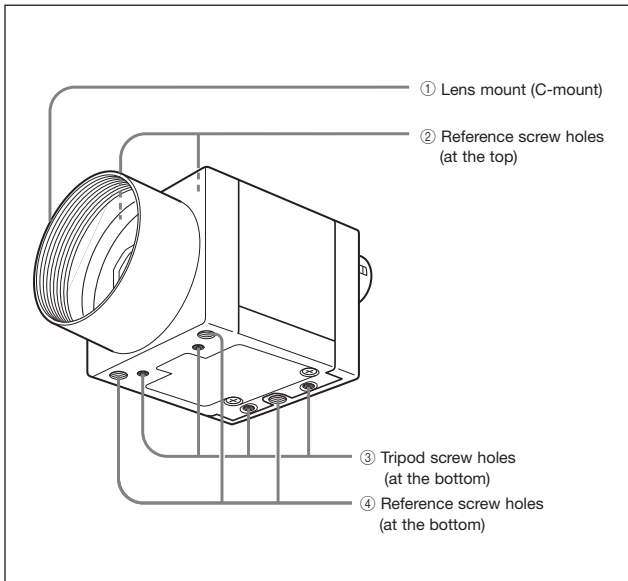

① Lens mount (C-mount)

Attach any C-mount lens or other optical equipment.

Note

Be sure that the lens does not project more than 10 mm from the lens mount.

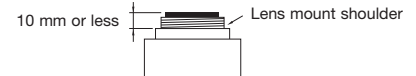

② Reference screw holes (at the top)

These screw holes help to lock the camera module.

③ Tripod screw holes (at the bottom)

These four screw holes on the bottom are for installing the camera module on a tripod. To install on a tripod, you will need to install the VCT-333I tripod adaptor using these holes on the bottom of the camera.

④ Reference screw holes (at the bottom)

These precision screw holes are for locking the camera module. Locking the camera module using these holes secures the optical axis alignment.

Specifications

	XC-HR50	XC-HR57
Image device	1/3-type progressive scan IT CCD	1/2-type progressive scan IT CCD
Effective picture elements (H) × (V)	659 × 494	648 × 494
Effective lines (H) × (V)	648 × 494	648 × 494
Image size (H) × (V)	VGA size: 648 × 494	
Cell size (H) × (V)	7.4 μm × 7.4 μm	9.9 μm × 9.9 μm
Lens mount	C-mount	
Sync system	Internal/External (auto)	
External sync signal input/output [†]	HD/VD (HD/VD level: 2 V to 5 Vp-p, 75 Ω)	
External sync allowable frequency	±1% (in horizontal sync frequency)	
Jitter	Less than 20 ns	
Scanning system	Non-interlace Progressive scan	
Output signal frequency	Binning: 2-line combined output 120 fps/Normal: 1-line sequential output 60 fps	
Video output	1.0 Vp-p, sync negative, 75 Ω, unbalanced	
CCD vertical drive frequency	31.468 kHz	
CCD horizontal drive frequency	59.94 MHz (normal mode), 119.88 Hz (binning mode)	
Horizontal resolution	500 TV lines	
Sensitivity	400 lx F5.6 (γ=OFF, FIX GAIN (0 dB))	
Minimum illumination	1 lx (F1.4, γ=OFF, GAIN 18 dB)	
S/N ratio	58 dB (0 dB GAIN)	
Gain	Manual (0 dB to 18 dB)/Fix (0 dB) (adjustable on the rear panel)	
Gamma	OFF (fixed)	
White clip	820 mV ±70 mV (F1.4, FIX GAIN (0 dB))	
Shutter	Normal shutter, Restart/Reset, External trigger shutter (Mode 1/Mode 2)	
Normal shutter speed (sec)	1/100, 1/125, 1/250, 1/500, 1/1,000, 1/2,000, 1/4,000, 1/10,000, 1/15,000, 1/30,000	
External trigger shutter speed (sec)	DIP switch settings: 1/100, 1/125, 1/250, 1/500, 1/1,000, 1/2,000, 1/4,000, 1/10,000, 1/25,000, 1/50,000, 1/100,000 Trigger pulse width settings: 1/4 to 1/100,000	
External trigger	Polarity: +, Width: 2 μs to 250 ms, Input impedance: 10 kΩ or more	
Partial scan	R/R mode Binning off: max 240 fps (effective line: 102 lines) Binning on: max 362 fps (effective line: 59 lines)	
	External trigger shutter mode (MODE 1) Binning off: max 240 fps (effective line: 100 lines) Binning on: max 240 fps (effective line: 105 lines)	
Power requirements	DC 12 V (10.5 V to 15.0 V)	
Power consumption	1.8 W	
Dimensions	29 (W) × 29 (H) × 30 (D) mm (not including projecting parts)	
Mass	50 g	
Operating temperature	-5°C to +45°C	
Storage temperature	-30°C to +60°C	
Performance guarantee temperature	0°C to 40°C	
Operating humidity	20% to 80% (no condensation)	
Storage humidity	20% to 95% (no condensation)	
Vibration resistance	10 G (20 Hz to 200 Hz) 20 minutes for each direction-x, y, z	
Shock resistance	70 G	
MTBF	88,044 hours (Approx. 10.1 years)	
Regulatory compliance	UL6500, FCC/ICES-003: Class A, CE: EN61326, AS/NZ: EN61326, KC: KN22/KN24: Class A	
Supplied accessories	Lens mount cap (1), Operating instructions (1)	

The values for mass and dimension are approximate.

[†] Automatic switching in response to the presence of an input signal when the switch on the rear panel is set to EXT.

Rear Panel

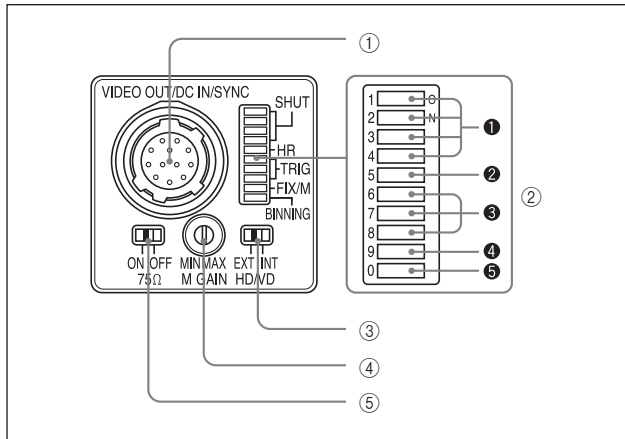

Note

Be sure to turn the power off before making switch settings. As the variable controller for manual adjustment is a small precise component, do not apply force more than required when adjusting. Doing so will break the component. The controller is not a 360-degree rotation type. Do not turn the controller beyond the stopper of the component. The range of rotation is about 260 degrees. For the adjustment of the variable controller, use a flathead screwdriver. The sizes of a recommended flathead screwdrivers are 1.9 mm width, 0.5 mm thickness and more than 0.45 mm length.

① VIDEO OUT/DC IN/SYNC (video output/DC power/sync input signal) connector (12-pin connector)

Connect a CCXC-12P05N camera cable to this connector to obtain power from the +12 V DC power supply and also to enable video signal output from the camera module. When a sync signal generator is connected to this connector, the camera module is synchronized with the external sync signals (HD/VD signals).

② Shutter speed/Mode setting DIP switch

① Shutter speed (bits 1 to 4)

Set an appropriate shutter speed (factory setting: OFF).

② Partial scan mode switch (bit 5)

The factory setting of this switch is Partial scan OFF. If you turn this switch ON to use Partial scan mode, you also need to make the external VD pulse rate and width settings.

③ Restart reset/External trigger shutter mode switch (bits 6 to 8)

By inputting an external restart/reset signal, you can capture the information of single screens at arbitrary timing. By inputting an external trigger signal, you can capture fast-moving objects at precise locations. The factory settings for these switches are for normal operation (restart/reset and external trigger shutter OFF).

④ Gain switch (bit 9)

This switch selects FIX (fixed) or MANUAL (manual adjustment) (factory setting: FIX (left side)).

⑤ Binning mode switch (bit 0)

Switches the video signal output mode between binning OFF and binning ON (factory setting: OFF).

③ HD/VD signal input/output switch

Set the switch to INT to output HD/VD signals from the camera module.

Set the switch to EXT to input HD/VD signals from an external unit (factory setting: EXT).

Note

Even when the switch is set to EXT, the camera module operates in internal synchronization mode when no external HD signal is input. In this case, however, the camera module will not output internal sync signals.

④ M Gain (Manual Gain) control knob

If you have selected MANUAL (manual adjustment) with DIP switch 4, this knob adjusts the gain.

⑤ 75 Ω termination switch

Turn this to OFF when not terminating the external sync signal (factory setting: ON).

Factory Mode Settings of Rear Panel

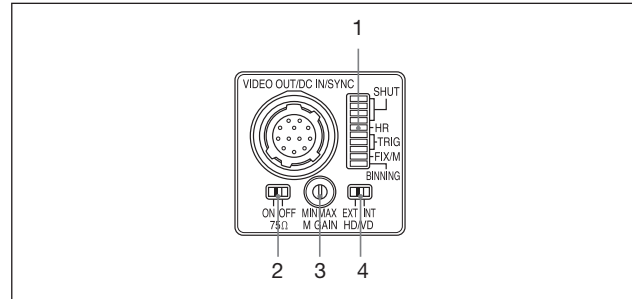

Number	Switch name	Factory mode setting
1	Shutter speed and mode setting DIP switches	All bits are OFF (left).
2	75 Ω termination switch	ON
3	M GAIN control knob	-*
4	HD/VD signal input/output switch	EXT

* This unit is shipped from the factory with the gain switch (DIP switch 9) being set to "FIX", so the M GAIN control knob is not operative unless the switch setting is changed. When the gain switch (DIP switch 9) is set to MANUAL, you can rotate this knob to adjust gain over the range 0 dB to 18 dB.

Connector Pin Assignments

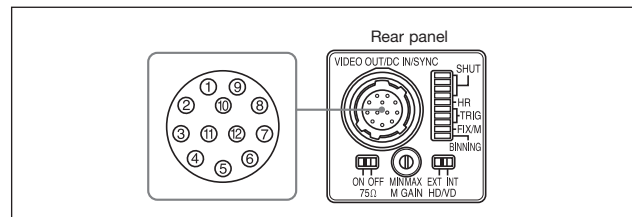

Pin No.	Camera sync output	External mode (HD/VD)	Restart/Reset	External trigger shutter
1	Ground	Ground	Ground	Ground
2	+12 V DC	+12 V DC	+12 V DC	+12 V DC
3	Video output (Ground)	Video output (Ground)	Video output 1 (Ground)	Video output (Ground)
4	Video output (Signal)	Video output (Signal)	Video output 1 (Signal)	Video output (Signal)
5	HD output (Ground)	HD input (Ground)	HD input (Ground)	HD input (Ground)
6	HD output (Signal)	HD input (Signal)	HD input (Signal)	HD input (Signal)
7	VD output (Signal)	VD input (Signal)	Reset (Signal)	VD input (Signal)
8	—	—	—	—
9	—	—	—	—
10	—	—	—	WEN output (Signal)
11	—	—	—	Trigger pulse input (Signal)
12	VD output (Ground)	VD input (Ground)	Reset (Ground)	Reset (Ground)*

* Common ground for pins 7, 10, and 11

About the Electronic Shutter

There are two shutter types: normal shutter and external trigger shutter. Select them with the DIP switches on the rear panel.

* The electronic shutter cannot be used in restart/reset mode. Partial scan can be used in restart/reset mode and in external trigger shutter mode 1.

Normal Shutter

This mode provides continuous video output with the electronic shutter selected by switches to capture a high-speed moving object clearly.

Normal Shutter	Other modes*
8	8

* "Other modes" refers to restart/reset mode and external trigger shutter mode.

• Normal shutter speed settings

1/125	1/250	1/500	1/1000
1 2 3 4	1 2 3 4	1 2 3 4	1 2 3 4
1/2000	1/4000	1/10000	1/15000
1 2 3 4	1 2 3 4	1 2 3 4	1 2 3 4
1/30000	1/100		
1 2 3 4	1 2 3 4		

(Unit: seconds)

External Trigger Shutter

Mode 1	Mode 2	Partial scannig
6 7 8	6 7 8	OFF ON 5 5

(Partial mode is compatible with Mode 1 only.)

Inputting an external trigger pulse enables the camera to capture first-moving objects clearly.

Set DIP switches 6, 7, and 8 on the rear panel to Mode 1 or Mode 2. When you set the trigger pulse width to 1/3 of a second or more, the output signal changes to the normal VIDEO signal.

Note

- After turning on the camera, since the first external trigger pulse is used for mode setting of the camera, the first frame image is invalid. This is the case for all modes when external trigger shutter is used.
- Partial scan mode cannot be used while in external trigger shutter mode 2.

There are two modes for the timing in which video signals are obtained.

• Mode 1 (Non-reset mode)

In this mode, a video signal synchronized with a VD signal is output after a trigger pulse is input.

- The video signal is synchronized with the external VD signal when an external HD*/VD signal is input.
- The video signal is synchronized with an internal VD signal when no external HD*/VD signal is input.

* External or internal synchronization is selected automatically depending on the presence or absence of external HD input.

• Mode 2 (Reset mode)

In this mode, an internal VD is reset, then a video signal is output a certain period of time after trigger pulse input.

To Set the External Trigger Shutter

There are two ways to set the shutter speed.

• Using trigger pulse width

Set all DIP switches (1 to 4 on the rear panel) to OFF.

You can obtain an arbitrary shutter speed by setting the trigger pulse width to the range of 2 μ sec to 250 msec.

Exposure time = Trigger pulse width + 6 μ sec

Mode 1
(Non-reset mode)



Mode 2
(Reset mode)

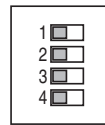

Note

An incorrect video signal will be output if you input a new trigger pulse before the video signal output for the previous trigger pulse is output completely.

• Using the DIP switches on the rear panel

For shutter speeds, see the following table.

Mode 1 (Non-reset mode)/Mode 2 (Reset mode)

1/125	1/250	1/500	1/1000
1 2 3 4	1 2 3 4	1 2 3 4	1 2 3 4
1/2000	1/4000	1/10000	1/25000
1 2 3 4	1 2 3 4	1 2 3 4	1 2 3 4
1/50000	1/100000	1/100	
1 2 3 4	1 2 3 4	1 2 3 4	

(Unit: seconds)

Restart/Reset

To Set Restart/Reset Mode

This mode allows you to capture the information on single screens at any time by externally inputting restart/reset signals (HD/VD). To enter this mode, set the trigger shutter switches (6 to 8) on the rear panel of the camera as shown in the figure below.

To use restart/reset mode and Partial scan mode simultaneously, set the Partial scan mode switch (5) to ON (right side).

Restart reset	High-rate scan
R/R 6 7 8	OFF ON 5 5

Long Exposure

The Restart/Reset function extends the CCD accumulation time, resulting in highly sensitive image capture. This function is effective when you cannot gain satisfactory sensitivity under normal operating conditions, or when you want to observe the trail of a moving object. Extend the VD interval (T) between external VD pulses.

