

XC-EU50/EU50CE

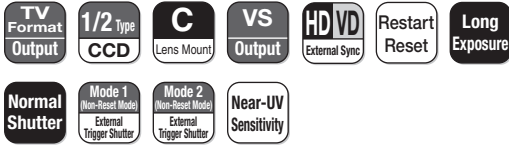

Connection Diagram **P98**



Outline

The XC-EU50/EU50CE is a monochrome video camera module with a 1/2-type CCD for industrial use. With its sensitivity around the near ultraviolet range (around 365 nm), utilized the feature of the shorter wavelength range characteristics and very detailed data can be detected. Small scratches, dust or blemishes hardly visible to the naked eye can be captured as a clear image by combining the camera with a light source that has a wavelength of about 360 nm. This model inherited compact size, rear panel mode switches from the XC-E series and is ideal for use in industrial applications.

Features

- XC-EU50/EU50CE: 1/2-type IT CCD
- Near-UV sensitivity
- High S/N ratio: 60 dB
- Electronic shutter function (1/100 sec to 1/10,000 sec)
- External trigger shutter function (1/4 sec to 1/10,000 sec)
- 2:1 Interlaced/non-interlaced
- Sync system: Internal/external (HD/VD)
- Frame/field accumulation
- Restart/reset function
- High shock and vibration resistance

Accessories

- Compact camera adaptor
 - DC-700/700CE
- 12-pin camera cable (CE standard)
 - CCXC-12P02N (2 m)
 - CCXC-12P05N (5 m)
 - CCXC-12P10N (10 m)
 - CCXC-12P25N (25 m)
- Tripod adaptor
 - VCT-333I

Dimensions

Camera body of all XC-E models

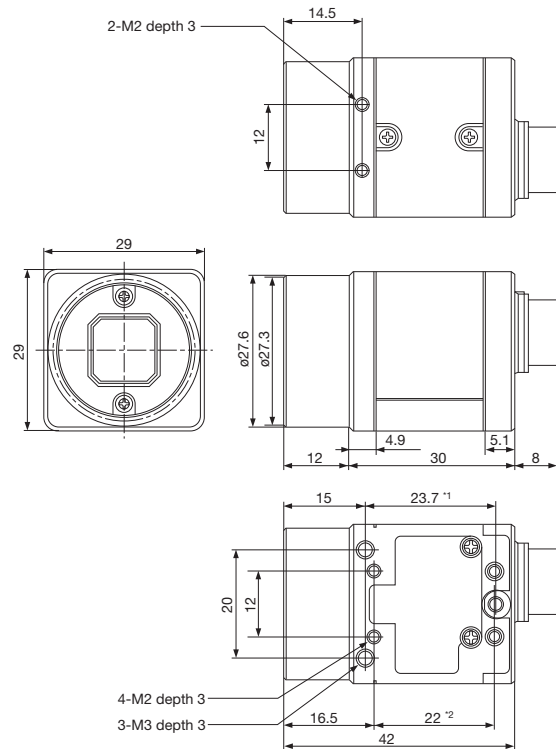

Unit: mm

*1: M3 screw size
*2: M2 screw size

Notice

From January 2005, the outside dimensions of XC-E series consoles will be changed to the same dimensions of XC-HR series consoles. For the new outside dimensions, see page 88. The outside dimensions will be changed from the following serial numbers.
XC-EU50: 250001
XC-EU50CE: 550001

Spectral Sensitivity Characteristics

• XC-EU50/XC-EU50CE

(Typical Values)

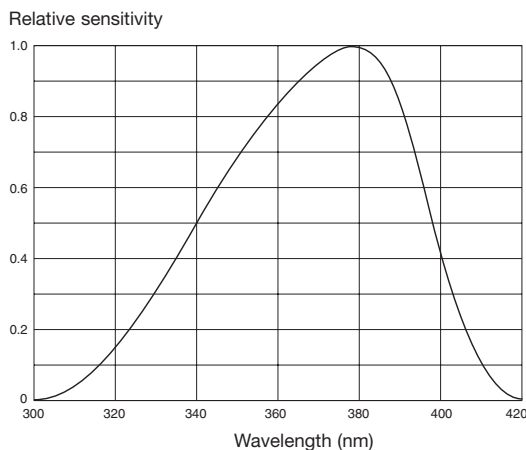

(Lens characteristics and light source characteristics excluded.)

Location and Function of Parts and Controls

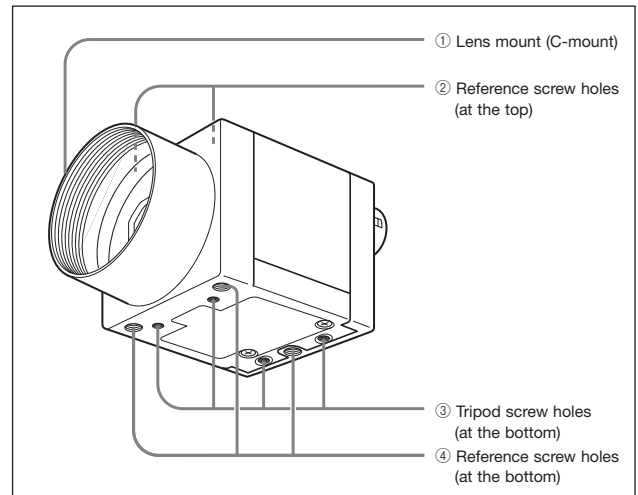

① Lens mount (C-mount)

Attach any C-mount lens or other optical equipment for Near UV.

Note

Be sure that the lens does not project more than 10 mm from the lens mount.

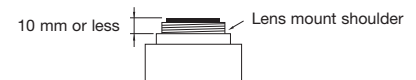

② Reference screw holes (at the top)

These screw holes help to lock the camera module.

③ Tripod screw holes (at the bottom)

These four screw holes on the bottom are for installing the camera module on a tripod. To install on a tripod, you will need to install the VCT-333I tripod adaptor using these holes on the bottom of the camera.

④ Reference screw holes (at the bottom)

These precision screw holes are for locking the camera module. Locking the camera module using these holes secures the optical axis alignment.

Specifications

	XC-EU50	XC-EU50CE
Image device	1/2-type IT CCD	
Signal system	EIA	CCIR
Effective picture elements (H) × (V)	768 × 494	752 × 582
Effective lines (H) × (V)	752 × 485	736 × 575
Cell size (H) × (V)	8.4 μm × 9.8 μm	8.6 μm × 8.3 μm
Horizontal frequency	15.734 kHz	15.625 kHz
Vertical frequency	59.94 Hz	50 Hz
Lens mount	C-mount	
Sync system	Internal/External (auto)	
External sync system input/output ¹⁾	HD/VD (HD/VD level: 2 Vp-p to 5 Vp-p)	
External sync frequency	±1% (automatic switching)	
Jitter	less than ±20 nsec (external horizontal frequency)	
Scanning system	2:1 Interlaced	
Video output	1.0 Vp-p, negative, 75 Ω unbalanced	
Horizontal resolution	570 TV lines	560 TV lines
S/N ratio	60 dB	
Gain	AGC/Manual (adjustable on the rear panel)	
Gamma	ON/OFF (adjustable on the rear panel)	
Normal shutter	1/100 sec to 1/10,000 sec	1/120 sec to 1/8,000 sec
External trigger shutter	1/4 sec to 1/10,000 sec	1/4 sec to 1/8,000 sec
Power requirements	DC 12 V (9 V to 16 V)	
Power consumption	1.6 W	
Dimension	29 (W) × 29 (H) × 30 (D) mm (not including projecting parts)	
Mass	50 g	
Operating temperature	-5°C to +45°C	
Storage temperature	-30°C to +60°C	
Performance guarantee temperature	0°C to 40°C	
Operating humidity	20% to 80% (no condensation)	
Storage humidity	20% to 80% (no condensation)	
Vibration resistance	10 G (20 Hz to 200 Hz 20 minutes for each direction-x, y, z)	
Shock resistance	70 G	
MTBF	126,469 hours (Approx. 14.4 years)	
Regulatory compliance	UL1492, FCC/ICES-003 : Class B, CE : EN61326, AS/NZ : EN61326	
Supplied accessories	Lens mount cap (1), Operating instructions (1)	

The values for mass and dimension are approximate.

¹⁾ Automatic switching in response to the presence of an input signal when the switch on the rear panel is set to EXT.

Rear Panel

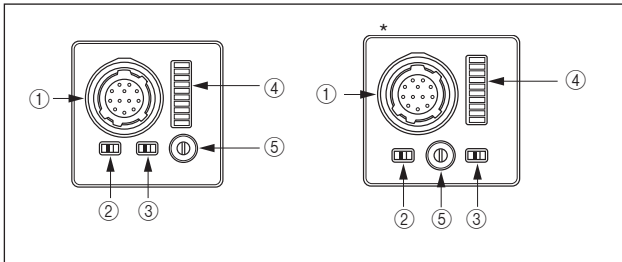
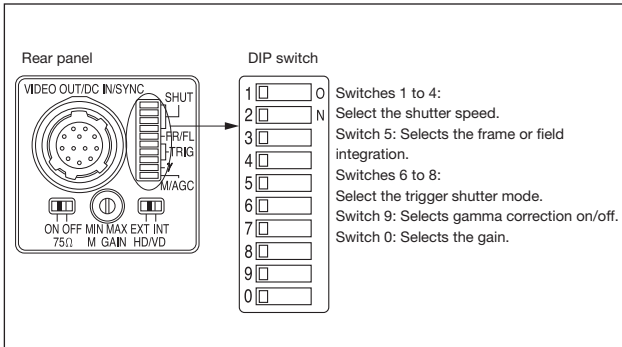

* The rear panel is different for the serial numbers shown below.
 XC-EU50 : 200001
 XC-EU50CE : 500001

Note

Be sure to turn the power off before making switch settings. As the variable controller for manual adjustment is a small precise component, do not apply force more than required when adjusting. Doing so will break the component. The controller is not a 360-degree rotation type. Do not turn the controller beyond the stopper of the component. The range of rotation is about 260 degrees. For the adjustment of the variable controller, use a flathead screwdriver. The sizes of a recommended flathead screwdrivers are 1.9 mm width, 0.5 mm thickness and more than 0.45 mm length.

- ① **12-pin multi-connector**
DC IN/HD/VD (DC power/sync signal input) VIDEO OUT terminal.
- ② **75 Ω termination selector switch**
- ③ **HD/VD input-output selector switch**
- ④ **Shutter speed/mode setting DIP switch**
- ⑤ **Volume control switch**
This switch can be changed in the range of Switch 0 to 18 dB when the GAIN switch is set to "M".
*During factory setting, this switch is adjusted to the mechanical center.

Note

When setting DIP switch 5 to the frame integration, set the volume control switch 8 to the MAX side from the mechanical center (because of CCD characteristics).

Factory Mode Settings of Rear Panel

No.	Switch	Factory-setting mode
②	75 Ω termination selector switch	ON
③	HD/VD input-output selector switch	EXT
④	Shutter speed/mode setting DIP switch	
	Switches 1 to 4: Select the shutter speed.	OFF
	Switch 5: Selects the frame or field integration.	FRAME
	Switches 6 to 8: Select the trigger shutter mode.	Normal
	Switch 9: Selects gamma correction on/off.	OFF
	Switch 0: Selects the gain.	Manual
⑤	Volume control switch	Mechanical center

Connector Pin Assignments

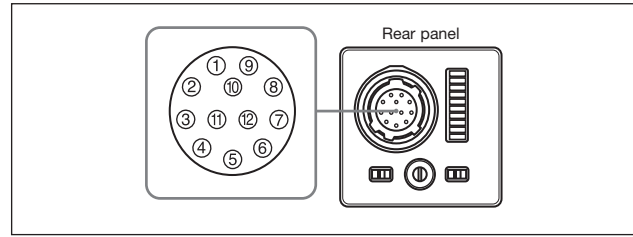

Pin No.	Camera sync output	External Sync (HD/VD)	Restart/Reset	External trigger shutter
1	Ground	Ground	Ground	Ground
2	+12 V DC	+12 V DC	+12 V DC	+12 V DC
3	Video output (Ground)	Video output (Ground)	Video output (Ground)	Video output (Ground)
4	Video output (Signal)	Video output (Signal)	Video output (Signal)	Video output (Signal)
5	HD output (Ground)	HD input (Ground)	HD input (Ground)	HD input (Ground)
6	HD output (Signal)	HD input (Signal)	HD input (Signal)	HD input (Signal)
7	VD output (Signal)	VD input (Signal)	Reset (Signal)	VD input (Signal)
8	—	—	—	—
9	—	—	—	—
10	—	—	—	WEN output (Signal)
11	—	—	—	Trigger pulse input (Signal)
12	VD output (Ground)	VD input (Ground)	Reset (Ground)	VD input (Ground)

Normal Shutter

This mode provides continuous video output with the electronic shutter selected by switches to capture a high-speed moving object clearly.

Setting of the Normal Shutter

- Using the DIP switches on the rear panel

Shutter OFF	1/125	1/250	1/500	1/1000
1 <input type="checkbox"/>	1 <input type="checkbox"/>	1 <input type="checkbox"/>	1 <input type="checkbox"/>	1 <input type="checkbox"/>
2 <input type="checkbox"/>	2 <input type="checkbox"/>	2 <input type="checkbox"/>	2 <input type="checkbox"/>	2 <input type="checkbox"/>
3 <input type="checkbox"/>	3 <input type="checkbox"/>	3 <input type="checkbox"/>	3 <input type="checkbox"/>	3 <input type="checkbox"/>
4 <input type="checkbox"/>	4 <input type="checkbox"/>	4 <input type="checkbox"/>	4 <input type="checkbox"/>	4 <input type="checkbox"/>
5 <input type="checkbox"/>	5 <input type="checkbox"/>	5 <input type="checkbox"/>	5 <input type="checkbox"/>	5 <input type="checkbox"/>
6 <input type="checkbox"/>	6 <input type="checkbox"/>	6 <input type="checkbox"/>	6 <input type="checkbox"/>	6 <input type="checkbox"/>
7 <input type="checkbox"/>	7 <input type="checkbox"/>	7 <input type="checkbox"/>	7 <input type="checkbox"/>	7 <input type="checkbox"/>
8 <input type="checkbox"/>	8 <input type="checkbox"/>	8 <input type="checkbox"/>	8 <input type="checkbox"/>	8 <input type="checkbox"/>
9 <input type="checkbox"/>	9 <input type="checkbox"/>	9 <input type="checkbox"/>	9 <input type="checkbox"/>	9 <input type="checkbox"/>
0 <input type="checkbox"/>	0 <input type="checkbox"/>	0 <input type="checkbox"/>	0 <input type="checkbox"/>	0 <input type="checkbox"/>
1/2000	1/4000	1/10000 (EIA) 1/8000 (CCIR)	Flickerless* (EIA: 1/100 CCIR: 1/120)	
1 <input type="checkbox"/>	1 <input type="checkbox"/>	1 <input type="checkbox"/>	1 <input type="checkbox"/>	
2 <input type="checkbox"/>	2 <input type="checkbox"/>	2 <input type="checkbox"/>	2 <input type="checkbox"/>	
3 <input type="checkbox"/>	3 <input type="checkbox"/>	3 <input type="checkbox"/>	3 <input type="checkbox"/>	
4 <input type="checkbox"/>	4 <input type="checkbox"/>	4 <input type="checkbox"/>	4 <input type="checkbox"/>	
5 <input type="checkbox"/>	5 <input type="checkbox"/>	5 <input type="checkbox"/>	5 <input type="checkbox"/>	
6 <input type="checkbox"/>	6 <input type="checkbox"/>	6 <input type="checkbox"/>	6 <input type="checkbox"/>	
7 <input type="checkbox"/>	7 <input type="checkbox"/>	7 <input type="checkbox"/>	7 <input type="checkbox"/>	
8 <input type="checkbox"/>	8 <input type="checkbox"/>	8 <input type="checkbox"/>	8 <input type="checkbox"/>	
9 <input type="checkbox"/>	9 <input type="checkbox"/>	9 <input type="checkbox"/>	9 <input type="checkbox"/>	
0 <input type="checkbox"/>	0 <input type="checkbox"/>	0 <input type="checkbox"/>	0 <input type="checkbox"/>	

(Unit: second)

* If you set the mode to flickerless, the positions of DIP switches 1 to 3 are optional.

Note

- The positions of DIP switches 6 and 7 are optional.
- The DIP switch 5 position is optional. (The field setting is recommended.) The field setting can obtain a sensitivity that is twice that of the frame setting.

External Trigger Shutter

By inputting an external trigger pulse, the camera is able to capture fast-moving objects clearly.

Set DIP switches 6, 7, and 8 on the rear panel to Mode 1 or Mode 2 (See the table below).

When you set the trigger pulse width to 1/3 of a second or more, the output signal changes to the normal VIDEO signal. There are two modes for timing in which a video signal is obtained.

• Mode 1 (Non-reset mode)

In this mode, a video signal synchronized with a VD signal is output after a trigger pulse is input.

- A video signal is synchronized with the external VD signal when an external HD/VD signal is input.
- A video signal is synchronized with an internal VD signal when no external HD/VD signal is input.

• Mode 2 (Reset mode)

In this mode, an internal VD is reset, then an internal video signal is output after trigger pulse input after a certain period of time.

Setting of the External Trigger Shutter

You can set the shutter speed with the DIP switches or using the trigger pulse width.

• Using the DIP switches on the rear panel

Mode 1 (Non-reset mode)				Mode 2 (Reset mode)			
1/100 (EIA)* 1/120 (CCIR)*	1/125	1/250	1/500	1/100 (EIA)* 1/120 (CCIR)*	1/125	1/250	1/500
1 <input type="checkbox"/>	1 <input type="checkbox"/>	1 <input type="checkbox"/>	1 <input type="checkbox"/>	1 <input type="checkbox"/>	1 <input type="checkbox"/>	1 <input type="checkbox"/>	1 <input type="checkbox"/>
2 <input type="checkbox"/>	2 <input type="checkbox"/>	2 <input type="checkbox"/>	2 <input type="checkbox"/>	2 <input type="checkbox"/>	2 <input type="checkbox"/>	2 <input type="checkbox"/>	2 <input type="checkbox"/>
3 <input type="checkbox"/>	3 <input type="checkbox"/>	3 <input type="checkbox"/>	3 <input type="checkbox"/>	3 <input type="checkbox"/>	3 <input type="checkbox"/>	3 <input type="checkbox"/>	3 <input type="checkbox"/>
4 <input type="checkbox"/>	4 <input type="checkbox"/>	4 <input type="checkbox"/>	4 <input type="checkbox"/>	4 <input type="checkbox"/>	4 <input type="checkbox"/>	4 <input type="checkbox"/>	4 <input type="checkbox"/>
5 <input type="checkbox"/>	5 <input type="checkbox"/>	5 <input type="checkbox"/>	5 <input type="checkbox"/>	5 <input type="checkbox"/>	5 <input type="checkbox"/>	5 <input type="checkbox"/>	5 <input type="checkbox"/>
6 <input type="checkbox"/>	6 <input type="checkbox"/>	6 <input type="checkbox"/>	6 <input type="checkbox"/>	6 <input type="checkbox"/>	6 <input type="checkbox"/>	6 <input type="checkbox"/>	6 <input type="checkbox"/>
7 <input type="checkbox"/>	7 <input type="checkbox"/>	7 <input type="checkbox"/>	7 <input type="checkbox"/>	7 <input type="checkbox"/>	7 <input type="checkbox"/>	7 <input type="checkbox"/>	7 <input type="checkbox"/>
8 <input type="checkbox"/>	8 <input type="checkbox"/>	8 <input type="checkbox"/>	8 <input type="checkbox"/>	8 <input type="checkbox"/>	8 <input type="checkbox"/>	8 <input type="checkbox"/>	8 <input type="checkbox"/>
9 <input type="checkbox"/>	9 <input type="checkbox"/>	9 <input type="checkbox"/>	9 <input type="checkbox"/>	9 <input type="checkbox"/>	9 <input type="checkbox"/>	9 <input type="checkbox"/>	9 <input type="checkbox"/>
0 <input type="checkbox"/>	0 <input type="checkbox"/>	0 <input type="checkbox"/>	0 <input type="checkbox"/>	0 <input type="checkbox"/>	0 <input type="checkbox"/>	0 <input type="checkbox"/>	0 <input type="checkbox"/>
1/1000	1/2000	1/4000	1/10000 (EIA) 1/8000 (CCIR)	1/1000	1/2000	1/4000	1/10000 (EIA) 1/8000 (CCIR)
1 <input type="checkbox"/>	1 <input type="checkbox"/>	1 <input type="checkbox"/>	1 <input type="checkbox"/>	1 <input type="checkbox"/>	1 <input type="checkbox"/>	1 <input type="checkbox"/>	1 <input type="checkbox"/>
2 <input type="checkbox"/>	2 <input type="checkbox"/>	2 <input type="checkbox"/>	2 <input type="checkbox"/>	2 <input type="checkbox"/>	2 <input type="checkbox"/>	2 <input type="checkbox"/>	2 <input type="checkbox"/>
3 <input type="checkbox"/>	3 <input type="checkbox"/>	3 <input type="checkbox"/>	3 <input type="checkbox"/>	3 <input type="checkbox"/>	3 <input type="checkbox"/>	3 <input type="checkbox"/>	3 <input type="checkbox"/>
4 <input type="checkbox"/>	4 <input type="checkbox"/>	4 <input type="checkbox"/>	4 <input type="checkbox"/>	4 <input type="checkbox"/>	4 <input type="checkbox"/>	4 <input type="checkbox"/>	4 <input type="checkbox"/>
5 <input type="checkbox"/>	5 <input type="checkbox"/>	5 <input type="checkbox"/>	5 <input type="checkbox"/>	5 <input type="checkbox"/>	5 <input type="checkbox"/>	5 <input type="checkbox"/>	5 <input type="checkbox"/>
6 <input type="checkbox"/>	6 <input type="checkbox"/>	6 <input type="checkbox"/>	6 <input type="checkbox"/>	6 <input type="checkbox"/>	6 <input type="checkbox"/>	6 <input type="checkbox"/>	6 <input type="checkbox"/>
7 <input type="checkbox"/>	7 <input type="checkbox"/>	7 <input type="checkbox"/>	7 <input type="checkbox"/>	7 <input type="checkbox"/>	7 <input type="checkbox"/>	7 <input type="checkbox"/>	7 <input type="checkbox"/>
8 <input type="checkbox"/>	8 <input type="checkbox"/>	8 <input type="checkbox"/>	8 <input type="checkbox"/>	8 <input type="checkbox"/>	8 <input type="checkbox"/>	8 <input type="checkbox"/>	8 <input type="checkbox"/>
9 <input type="checkbox"/>	9 <input type="checkbox"/>	9 <input type="checkbox"/>	9 <input type="checkbox"/>	9 <input type="checkbox"/>	9 <input type="checkbox"/>	9 <input type="checkbox"/>	9 <input type="checkbox"/>
0 <input type="checkbox"/>	0 <input type="checkbox"/>	0 <input type="checkbox"/>	0 <input type="checkbox"/>	0 <input type="checkbox"/>	0 <input type="checkbox"/>	0 <input type="checkbox"/>	0 <input type="checkbox"/>

(Unit: second)

* If 1/100 (EIA) or 1/120 (CCIR) has been set, the positions of DIP switches 1 to 3 are optional.

Note

The positions of DIP switches 5, 9 and 0 are optional.

• Setting the external shutter speed with the trigger pulse width

Set all DIP switches (1 to 4 on the rear panel) to 0.

You can obtain an arbitrary shutter speed by setting the trigger pulse width to the range of 2 μ s to 250 ms.

Mode 1 (Non-reset mode)

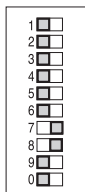

Mode 2 (Reset mode)

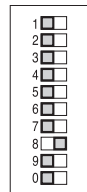

Exposure time = Trigger pulse width + 97 μ s (EIA)

Trigger pulse width + 120 μ s (CCIR)

Note

- The DIP switch 5 position is optional. (The field setting is recommended.) The field setting can obtain a sensitivity that is twice that of the frame setting.
- If you input a new trigger pulse before the video signal output for the previous trigger pulse is output completely, an incorrect video signal will be output.

• Specifications of the Trigger Pulse

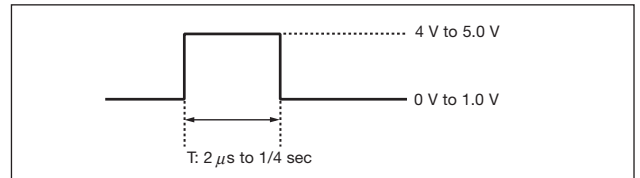

T: If you set the trigger pulse with the DIP switches, use the 100 μ s to 1/4 sec pulse width.

- Input impedance; 10 k Ω or more.
- The voltage and pulse width used are measured at pin 11 of a 12-pin multi-connector on the rear panel.

Restart/Reset

To Set Restart/Reset Mode

The information on one screen can be extracted at any time by externally inputting a restart/reset signal (HD/VD). To enter this mode, set DIP switches 6, 7, and 8 on the rear panel of the camera as shown in the figure below. The setting is especially effective for the operation explained below.

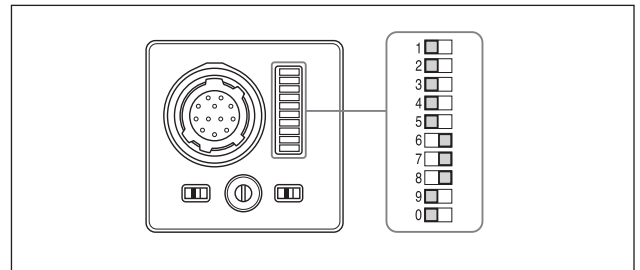

Long Exposure

The Restart/Reset function extends the CCD accumulation time, resulting in a highly sensitive image. This function is effective when you cannot gain satisfactory sensitivity under normal operating conditions, or when you want to observe a moving object. Extend the VD interval (T) period between external VD pulses.

Note

Some white spots may appear after a long exposure.

Sample input timing chart 1

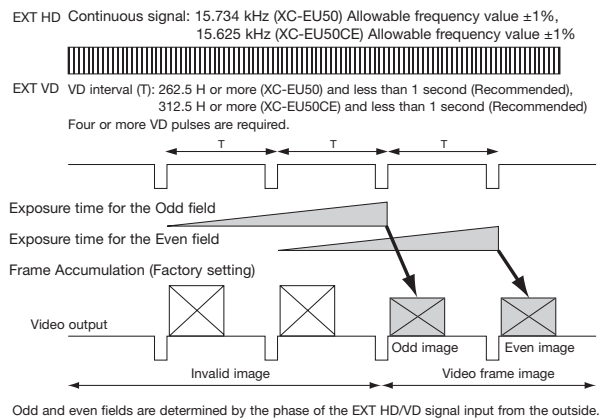

Information of XC-E Series Console Modification

From January 2005, the outside dimensions of XC-E series consoles will be changed to the same dimensions of XC-HR series consoles.

New Dimensions

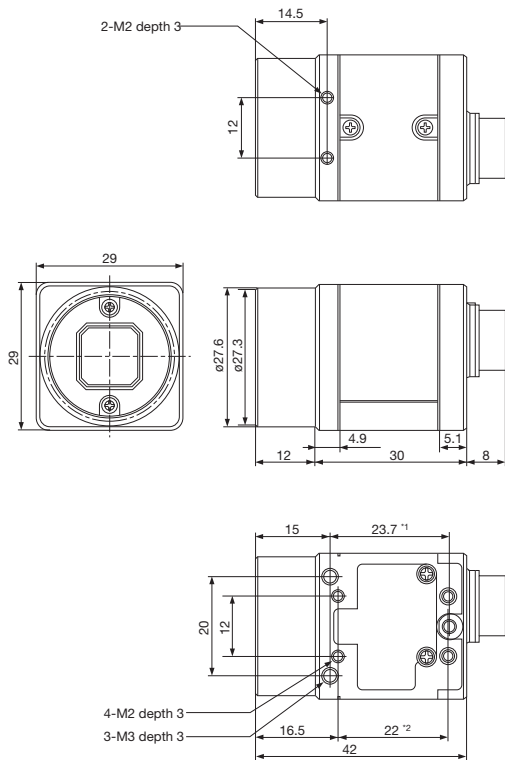

Unit: mm

*1: M3 screw size
*2: M2 screw size

Old Dimensions

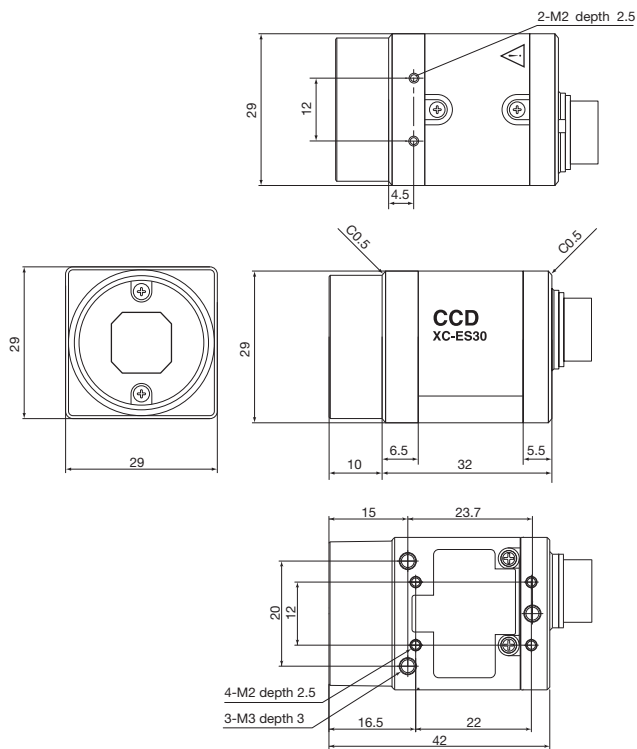

Unit: mm

The outside dimensions will be changed from the following serial number.

XC-ES50/ES30	: 250001
XC-ES50CE/ES30CE	: 550001
XC-ES51	: 150001
XC-ES51CE	: 450001
XC-EI50/EI30	: 250001
XC-EI50CE/EI30CE	: 550001
XC-EU50	: 250001
XC-EU50CE	: 550001

Digital Video Camera
XCG XCD XCL

Intelligent
XCI

Analog Video Camera
XC (Non-TV Format)

XC (TV Format)

Accessories

Color Camera Module
FCB

Color PTZ Camera
EVI